

# THE Radio Constructor

APRIL 1966

2/3

RADIO • TELEVISION  
ELECTRONICS • AUDIO

## Transistorised A.C. Millivoltmeter

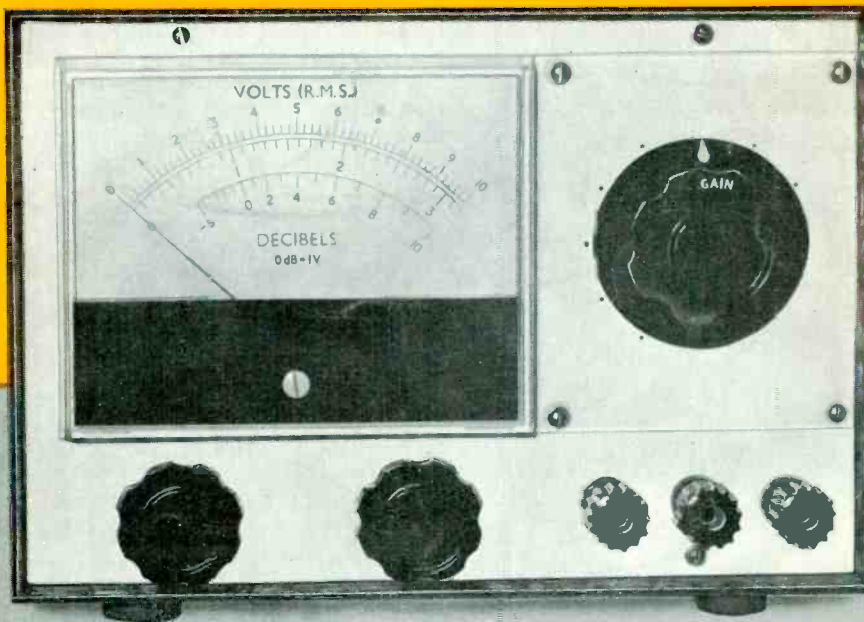

Receiver Circuit  
for Caravans



Economy Parking  
Light Controller



Home or Office  
Intercom System



Single Transistor  
Audio Oscillator



# Eddystone RECEIVER

OF MAJOR INTEREST TO ALL RADIO ENTHUSIASTS

## EC 10 transistorized communications receiver

A most efficient transistorized communications receiver of light weight, compact dimensions, and capable of a really good performance. Five ranges give continuous coverage from 550 kc/s to 30 Mc/s (545 to 10 metres), and included are the medium-wave broadcast band, the marine (coastal) band from 1500 to 3000 kc/s, and all the short-wave broadcast bands. Also available are the six major amateur bands and many services in between.

The EC10 receiver accepts normal AM telephony and CW telegraphy, a special filter being provided to increase selectivity (and also reduce noise) in the CW mode, as is often desirable. Single sideband signals can



be successfully resolved by appropriate setting of the BFO for carrier reinsertion. A total of 13 transistors and diodes is used, leading to high sensitivity and consistent results on all ranges. The main scales occupy a length of nine inches and are clearly calibrated direct in frequency. The standard Eddystone precision slow-motion drive controls the tuning, which is exceptionally smooth and light to handle. An auxiliary logging scale permits dial settings of chosen stations to be recorded.

An internal speaker gives good aural quality and a comparatively high audio output is available—one can easily believe the set is mains operated. For personal listening, a telephone headset can be plugged into the socket on the front panel, the speaker then being out of action.

Alternative aerial sockets are provided, for dipole, long wire, or short rod or wire. Power is derived from six cells housed in a separate detachable compartment. Current consumption is related to audio output and, for long life, HP2-type heavy-duty cells are recommended.

The receiver is housed in a metal cabinet, and, with robust construction throughout, it will stand up to hard usage over a long period with a high degree of reliability. The finish is an attractive two-tone grey. The dimensions are width  $12\frac{1}{2}$ " , height  $6\frac{3}{4}$ " , depth 8" ; weight with batteries is 14 lb.

## Eddystone Radio Limited

Eddystone Works, Alvechurch Road, Birmingham 31

Telephone: Priory 2231 · Cables: Eddystone Birmingham · Telex: 33708

LTD/ED5

# FREE TO AMBITIOUS ENGINEERS

— THE LATEST EDITION OF ENGINEERING OPPORTUNITIES

**Have you sent for your copy?**  
**ENGINEERING OPPORTUNITIES** is a highly informative 156-page guide to the best paid engineering posts. It tells you how you can quickly prepare at home for a recognised engineering qualification and outlines a wonderful range of modern Home Study Courses in all branches of Engineering. This unique book also gives full details of the Practical Radio & Electronics Courses, administered by our Specialist Electronics Training Division—the **B.I.E.T. School of Electronics**, explains the benefits of our Employment Dept. and shows you how to qualify for five years' promotion in one year.

## SATISFACTION OR REFUND OF FEE

Whatever your age or experience, you cannot afford to miss reading this famous book. If you are earning less than £30 a week, send for your copy of "ENGINEERING OPPORTUNITIES" today—FREE.

**BRITISH INSTITUTE OF ENGINEERING TECHNOLOGY**  
 (Dept. 752B), 29 Wright's Lane, London, W.8

**THE B.I.E.T. IS THE LEADING INSTITUTE OF ITS KIND IN THE WORLD**

### WHICH IS YOUR PET SUBJECT?

Mechanical Eng.,  
 Electrical Eng.,  
 Civil Engineering,  
 Radio Engineering,  
 Automobile Eng.,  
 Aeronautical Eng.,  
 Production Eng.,  
 Building, Plastics,  
 Draughtsmanship,  
 Television, etc.

### GET SOME LETTERS AFTER YOUR NAME!

A.M.I.Mech.E.  
 A.M.I.C.E.  
 A.M.I.Prod.E.  
 A.M.I.M.I.  
 A.I.O.B.  
 B.Sc.  
 A.M.I.E.R.E.  
 City & Guilds  
 Gen. Cert. of Ed.  
 Etc., etc.

### PRACTICAL EQUIPMENT

Basic Practical and Theoretic Courses for beginners in Radio, T.V. Electronics, Etc., A.M.I.E.R.E., City & Guilds, Radio Amateurs' Exam. R.T.E.B. Certificate P.M.G. Certificate Practical Radio Radio & Television Servicing Practical Electronics Electronics Engineering Automation

### INCLUDING TOOLS!

The specialist Electronics Division of B.I.E.T. NOW offers you a real laboratory training at home with practical equipment. Ask for details.

**B. I. E. T. SCHOOL OF ELECTRONICS**

### POST COUPON NOW!

Please send me your FREE 156-page "ENGINEERING OPPORTUNITIES" (Write if you prefer not to cut page)

NAME .....

ADDRESS .....

SUBJECT OR EXAM THAT INTERESTS ME .....

752B



## L.P. RECORDING TAPE

### BARGAIN OFFER!

By leading British manufacturers—

**PROFESSIONAL GRADE — DOUBLE-SIDED**  
 (each side coated) 5 1/2" reels only

**SPECIAL 1,450 feet (2 reels)**

**PRICE 20/- post free**

Ideal for the experimenter who wants to record both sides, and a good L.P. Tape for the enthusiast who wishes to record single side only.

**SPECIAL OFFER.** 3" Message tape 150', 3/9; 3" L.P. 225', 4/9; 3" D.P. 300', 6/6. P. & P. per reel 6d.  
**TAPE REELS.** Mfrs. surplus 7", 2/3; 5 1/2", 2/-; 5", 2/-; 3", 1/3; Plastics spool containers, 5", 1/9; 5 1/2", 2/-; 7", 2/3.

**TYGAN FRET** (Contem. pat.), 12 x 12", 2/-; 12 x 18", 3/-; 12 x 24", 4/-, etc.  
**EXPANDED ANODISED METAL**—Attractive gilt finish 1/2" x 3/4" diamond mesh 4/6 sq. ft. Multiples of 6" cut. Max. size 4' x 3', 47/6 plus carr.  
**BONDACOUST Speaker Cabinet** Acoustic Wadding (1" thick approx.) 18" wide, any length cut, 6/- yd.

**ENAMELLED COPPER WIRE**—1/16, 1/8, 1/4, 3/16, 1/2, 5/8, 3/4, 7/8, 1" diam. 30g-34g, 4/3; 36g-38g, 4/9; 39g-40g, 5/-, etc.  
**TINNED COPPER WIRE.** 16-22g, 4/- 1/6.  
**ERSIN MULTICORE SOLDER.** 60/40, 4d. Per yard, Cartons 6d., 1/-, 2/6, etc.

## 6 VALVE AM/FM TUNER UNIT

Med. and VHF 190m-550m, 86 Mc/s-103 Mc/s, 6 valves and metal rectifier. Self-contained power-unit, A.C. 200/250V operation. Magic-eye indicator, 3 push-button controls, on/off, Med., VHF. Diode and high output Sockets with gain control. Illuminated 2-colour perspex dial 1 1/2" x 4", chassis size 1 1/2" x 4" x 5 1/2". A recommended Fidelity Unit for use with Mullard "3-3" or "5-10" Amplifiers.  
 Complete kit of Parts, inc. Power Pack, £10.19.6, carriage and insurance as illustrated. Carr. 7/6. Circuit and constr's details, 4/6 Free with kit.



## MULLARD "3-3" & "5-10" HI-FI AMPLIFIERS

**3 OHM & 15 OHM OUTPUT "3-3"** Amp. 3-valve, 3 watt Hi-Fi quality at reasonable cost. Bass Boost and Treble controls, quality sectional output transformer, 40 c/s-25 kc/s 1 dB, 100mV for 3W, less than 1% distortion. Bronze escutcheon Panel. Complete Kit only 7 gns. Carr. 5/-. Wired and tested £8.10.0.  
**MULLARD "5-10" AMPLIFIER**—5 valves 10W, 3 and 15 ohms output. Mullard's famous circuit with heavy duty ultra-linear quality output trf. Basic amplifier kit price £9.19.6. Carr. 7/6. Ready built 1 1/2 gns.  
**2-VALVE PRE-AMP. UNIT** Based on Mullard's famous 2-valve (2 x EF86) circuit with full equalisation with volume, bass, treble, and S-position selector switch. Size 9" x 6" x 2 1/4". Ready built, wired and tested, £7.19.6. Carr. 3/6.

Condensers—Silver Mica. All values 2pF-100pF, 6d. each. Dittos 575pF-5,000pF, 1/6. Resistors—Full Range 10 ohms-10 meg. ohms 20% 1 and 1/2V, 3d., 1/2V, 5d. (Midgate type modern rating) 1W, 6d., 2W, 9d., 1/6. 0.0-1.900V, 1/-, 0.25 Hunt, 1/6. 0.25 T.C.C., 1/9, etc., etc. Close Tol. S/Micas—10% 50pF-500pF, 8d., 600-5,000pF, 1/-, 1% 1 1/2V, 1/6, etc., etc.



Send for detailed bargain lists, 3d. stamp. We manufacture all types Radio Mains Transf. Chokes. Quality O/P Trans., etc. Enquiries invited for Specials, Prototypes for small production runs. Quotation by return.

### RADIO COMPONENT SPECIALISTS

70 Brigstock Road, Thornton Heath, Surrey THO 2188. Hours: 9 a.m.-6 p.m., 1 p.m. Wed. Terms C.W.O. or C.O.D. Post and Packing up to 1/6, 1/-, 1/6. 1/9, 3/6, 3/-, 5/6, 3/9, 8/6, 4/6.

## TRANSISTOR COMPONENTS

Midget I.F.'s—465 kc/s 1/8" diam., 5/6  
 first, second or third  
 Osc. coil M. & L.W. 1/2" diam. 5/6  
 Midget Driver Trans. 9/1 6/-  
 Ditto O/Put Push-pull 3 ohms 6/-  
**Elect. Condensers**—Midget Type 15V 1mfd-50mfd, ea. 1/9. 100mfd, 2/-, 15 choke, 2/6.  
**Ferrite Aerial**—M. & L. W. with ca aerial coupling coil, 9/3.  
**Condensers**—150V wkg. .01mfd. to .04mfd., 9d. .05mfd., 1mfd., 1/-, .25mfd., 1/3. .5mfd., 1/6, etc.  
**Tuning Condensers.** J.B. "OO" 208 + 176pF, 8/6. Ditto with trimmers, 9/6. 365pF single, 7/6. Sub-min. 2" DILEMIN 100pF, 300pF, 500pF, 7/-.  
**Midget Vol. Control** with edge control knob, 5kΩ with switch, 4/9, ditto less switch, 3/9.

## TUB-ELECTROLYTICS-CAN

25/25V, 50/12V, 1/9; 8+8/450V, 4/6; 50/50V, 100/125V, 2/-; 32+32/275V, 4/6; 8/450V, 4/350V, 2/3; 50/50/350V, 6/6; 16+16/450V, 5/6; 60/250/275V, 12/6; 32+32/450V, 6/6; 100+200/275V, 12/6.

**Volume Controls**—SK-2 Meg-ohms, 3" Spindles Morganite Midget Type, 1 1/2" diam. Guar. 1 year. LOG or LIN ratios less Sw., 3/6. DP, Sw., 5/-. Twin Stereo less Sw., 7/6. D.P. Sw., 9/6 (100 k to 2 Meg. only). 1/2" Meg. VOL Controls D.P. Sw. 1/2" flatted spindle. Famous Mfrs. 3/4 for 10/- post free.

**Jack Plugs.** Standard 2 1/2" Igranic Type, 2/6. Screened Ditto, 3/3. Miniature scr. 1 1/2", 2/3. Sub-min., 1/3.  
**Jack Sockets.** Open Igranic Moulded Type, 3/6. Closed Ditto, 4/-. Miniature Closed Type, 1/6. Sub-min. (deaf aid) ditto, 1/6. Stereo Jack Sockets, 3/6. Stereo Jack Plugs, 3/6.

**Phono Plugs.** 9d. Phono Sockets (open), 9d. Ditto (closed), 1/-, Twin Phono Sockets (open), 1/3.

## HI-FI AMPLIFIERS ~~~~~ TUNERS ~~~~~ RECORD PLAYERS

20+20  
STEREO  
AMP.  
AA-22U



GARRARD  
PLAYER  
AT-60



10W  
POWER  
AMP.  
MA-12



3+3W  
STEREO  
AMP.  
S-33H

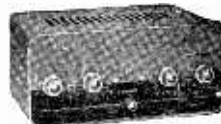

**TRANSISTOR MIXER. Model TM-1.** A must for the tape enthusiast. Four channels. Battery operated. Similar styling to Model AA-22U Amplifier. Kit £11.16.6 Assembled £16.17.6

**20+20W TRANSISTOR STEREO AMPLIFIER. Model AA-22U.** Outstanding performance and appearance. Kit £39.10.0 (less cabinet). Attractive walnut veneered cabinet £2.5.0 extra.

**GARRARD AUTO/RECORD PLAYER. Model AT-60.** less cartridge £13.1.7 With Decca Deram pick-up £17.16.1 incl. P.T. Many other Garrard models available, ask for Lists.

**HI-FI MONO AMPLIFIER. Model MA-5.** A general purpose 5W Amplifier, with inputs for Gram., Radio. Presentation similar to S-33. Kit £10.19.6 Assembled £15.10.0

**HI-FI MONO AMPLIFIER. Model MA-12.** 10W output, wide freq. range, low distortion. Kit £11.18.0 Assembled £15.18.0

**3 + 3W STEREO AMPLIFIER. Model S-33.** An easy-to-build, low cost unit. 2 inputs per channel. Kit £13.7.6 Assembled £18.18.0

**DE LUXE STEREO AMPLIFIER. Model S-33H.** De luxe version of the S-33 with two-tone grey perspex panel, and higher sensitivity necessary to accept the Decca Deram pick-up. Kit £15.17.6 Assembled £21.7.6

**HI-FI STEREO AMPLIFIER. Model S-99.** 9 + 9W output. Ganged controls. Stereo/Mono gram., radio and tape inputs. Push-button selection. Printed circuit construction. Kit £28.9.6 Assembled £38.9.6

**POWER SUPPLY UNIT. Model MGP-1.** Input 100/120V, 200/250V, 40-60 c/s. Output 6.3V, 2.5A A.C. 200, 250, 270V, 120mA max. D.C. Kit £5.2.6 Assembled £6.12.6



# HEATHKIT at 'The GRAND'

## FOR THE INSTRUMENTALIST

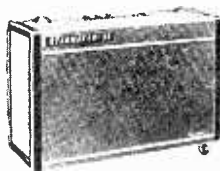

PA-2

**TRANSISTOR PA/GUITAR AMPLIFIER, PA-2.** 20 Watt amplifier. Two heavy duty speakers. Four inputs. Two channels. Variable tremolo. Speed and depth controls. Weight 51lb. 18" high x 29" wide x 10" deep. Kit £44.19.0 Assembled £59.10.0

**VALVE PA/GUITAR AMPLIFIER, PA-1.** 50 Watt amplifier. Kit £54.15.0 Assembled £74.0.0  
Castors or legs available as extras.

## INSTRUMENTS

**[NEW] 3" LOW-PRICED SERVICE OSCILLOSCOPE. Model OS-2.** Compact size 5" x 7 1/4" x 12" deep. Wt. only 9 1/2 lb. "Y" bandwidth 2 c/s-3 Mc/s ± 3dB. Sensitivity 100mV/cm. T/B 20 c/s-200 kc/s in four ranges, fitted mu-metal CRT Shield. Modern functional styling. Kit £22.18.0 Assembled £30.8.0

**5" GEN-PURPOSE OSCILLOSCOPE. Model 10-12U.** An outstanding model with professional specification and styling. "Y" bandwidth 3 c/s-4.5 Mc/s ± 3dB. T/B 10 c/s-500 kc/s. Kit £35.17.6 Assembled £45.15.0

**DE LUXE LARGE-SCALE VALVE VOLT-METER. Model IM-13U.** Circuit and specification based on the well-known model V-7A but with many worth-while refinements. 6" Ernest Turner meter. Unique gimbal bracket allows operation of instrument in many positions. Modern styling. Kit £18.18.0 Assembled £26.18.0

**AUDIO SIGNAL GENERATOR. Model AG-9U.** 10 c/s to 100 kc/s, switch selected. Distortion less than 0.1%, 10V sine wave output metered in volts and dB's. Kit £22.10.0 Assembled £30.10.0

**VALVE VOLT-METER. Model V-7A.** 7 voltage ranges d.c. volts to 1,500. A.c. to 1,500 r.m.s. and 4,000 peak to peak. Resistance 0.1Ω to 1,000MΩ with internal battery. D.c. input resistance 11MΩ. dB measurement, has centre-zero scale. Complete with test prods, leads and standardising battery. Kit £13.18.6 Assembled £19.18.6

**MULTIMETER. Model MM-1U.** Ranges 0-1.5V to 1,500V a.c. and d.c.; 150μA to 15A d.c.; 0.2Ω to 20MΩ. 4 1/2" 50μA meter. Kit £12.18.0 Assembled £18.11.6

**R.F. SIGNAL GENERATOR. Model RF-1U.** Up to 100 Mc/s fundamental and 200 Mc/s on harmonics. Up to 100mV output. Kit £13.8.0 Assembled £19.18.0

**[NEW] SINE/SQ GENERATOR. Model IG-82U.** Freq. range 20 c/s-1 Mc/s in 5 bands less than 0.5% sine wave dist. less than 0.15μ sec. sq. wave rise time. Kit £24.10.0 Assembled £36.10.0

**TRANSISTOR POWER SUPPLY. Model IP-20U.** Up to 50V, 1.5A output. Ideal for Laboratory use. Compact size. Kit £35.18.0 Assembled £47.18.0



OS-2

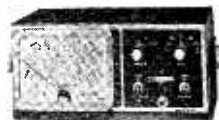

IM-13U



V-7A



RF-1U



IG-82U

Prices and specifications  
subject to change without  
notice

## TRANSISTOR RECEIVERS



UXR-2



UXR-1



UJR-1

**"OXFORD" LUXURY PORTABLE. Model UXR-2.** Specially designed for use as a domestic, car or personal portable receiver. Many features, including solid leather case. Kit £14.18.0 incl. P.T.

**TRANSISTOR PORTABLE. Model UXR-1.** Pre-aligned I.F. transformers, printed circuit. Covers L.W. and M.W. Has 7" x 4" loud-speaker. Real hide case. Kit £12.11.0 incl. P.T.

**JUNIOR EXPERIMENTAL WORKSHOP. Model EW-1.** More than a toy! Will make over 20 exciting electronic devices, incl: Radios, Burglar Alarms, etc. 72 page Manual. The ideal present! Kit £7.13.6 incl. P.T.

**JUNIOR TRANSISTOR RADIO. Model UJR-1.** Single transistor set. Excellent introduction to radio. Kit £2.7.6 incl. P.T.

WELCOME TO OUR LONDON HEATHKIT CENTRE  
233 Tottenham Court Road

We open MONDAY - SATURDAY 9 a.m. - 5.30 p.m.  
THURSDAY ... .. 11 a.m. - 2.30 p.m.

Telephone No: MUSeum 7349

WHEN YOU ARE IN TOWN, WE HOPE YOU WILL VISIT US THERE

## TAPE AMPLIFIERS ~~~~~ TAPE DECKS ~~~~~ CONTROL UNITS



**FM TUNER  
FM-4U**

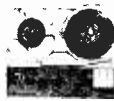

**MAGNAVOX  
Tape DECK**



**TRUVOX  
Tape DECK**



**AM/FM  
TUNER**

**HI-FI FM TUNER. Model FM-4U.** Also available in two units. R.F. tuning unit (£2.15.0 incl. P.T.) with I.F. output of 10.7 Mc/s, and I.F. amplifier unit, with power supply and valves (£13.13.0).

Total Kit **£16.80**

**MAGNAVOX "363" TAPE DECK.** The finest buy in its price range. Operating speeds: 1 1/2", 3 1/4" and 7 1/2" p.s. Two tracks, "wow" and "flutter" not greater than 0.15% at 7 1/2" p.s. **£13.10.0**

**HI-FI AM/FM TUNER. Model AFM-1.** Available in two units which, for your convenience, are sold separately. Tuning heart (AFM-T1—£4.13.6 incl. P.T.) and I.F. amplifier (AFM-A1—£22.11.6). Printed circuit board, 8 valves. Covers L.W., M.W., S.W., and F.M. Built-in power supply. **£27.5.0**

**TRUVOX D-93 TAPE DECKS.** High quality stereo/mono tape decks. D93/2, 1/4 track, **£36.15.0** D93/4, 1/4 track, **£36.15.0**

**TAPE RECORDING/PLAYBACK AMPLIFIER.** Thermometer type recording indicators, press-button speed compensation and input selection. Mono Model TA-1M. Kit **£19.18.0** Assembled **£28.18.0**  
Stereo Model TA-1S. Kit **£25.10.0** Assembled **£35.18.0**

**MONO CONTROL UNIT. Model UMC-1.** Designed to work with the MA-12 or similar amplifier requiring 0.25V or less for full output. 5 inputs. Baxandall type controls. Kit **£8.12.6** Assembled **£13.12.6**

**STEREO CONTROL UNIT. Model USC-1.** Push-button selection, accurately matched ganged controls to ±1dB. Rumble and variable low-pass filters. Printed circuit boards. Kit **£19.10.0** Assembled **£26.10.0**

**See the Heathkit exhibition and demonstration as usual at  
THE GRAND HOTEL, SOUTHAMPTON ROW, LONDON**  
APRIL 14-17 inclusive 11 a.m.-9 p.m. (8 p.m. Sunday) **ADMISSION FREE**



**SSU-1**

### SPEAKER SYSTEMS

**HI-FI SPEAKER SYSTEM. Model SSU-1.** Ducted-port bass reflex cabinet "in the white". Two speakers. Vertical or horizontal models with legs, Kit **£12.12.0**, without legs, Kit **£11.17.6** incl. P.T.

**[NEW] BERKELEY Slim-line SPEAKER SYSTEM,** fully finished walnut veneered cabinet for faster construction. Special 12" bass unit and 4" mid/high frequency unit. Range 30-17,000 c/s. Size 26" x 17" x only 7 1/4" deep. Modern attractive styling. Excellent value.

Kit **£18.10.0** Assembled **£23.0.0**

**COTSWOLD SPEAKER SYSTEMS.** Outstanding performance for price.

*MFS:* Size 36" x 16 1/2" x 14" deep.

Kit **£25.12.0** Assembled **£33.17.0**

*STANDARD:* Size 26" x 23" x 14 1/2" deep.

Kit **£25.12.0** Assembled **£33.17.0**



**Berkeley**

### HI-FI CABINETS

A wide range available including:

**GLOUCESTER.** Kit **£18.10.0** incl. P.T.

**MALVERN.** Kit **£18.1.0** incl. P.T.

**CHEPSTOW.** Kit **£11.12.6** incl. P.T.

We can also make available the well-known RECORD HOUSING range of fully finished cabinets.



**Malvern**

**SEND FOR THE LATEST  
FREE CATALOGUE**

Deferred terms available in U.K. over **£10**.  
Prices quoted are Mail Order prices.

**DAYSTROM LTD** DEPT. RC.4  
GLOUCESTER

### "AMATEUR" EQUIPMENT

**THE "MOHICAN" GENERAL COVERAGE RECEIVER. Model GC-1U.** With 4 piezo-electric transmitters, variable tuned B.F.O. and Zener diode stabiliser, this is an excellent fully transistorised general purpose receiver for Amateur and Short wave listeners. Printed circuits, telescopic aerial, tuning meter and large slide-rule dial. Kit **£37.17.6** Assembled **£45.17.6**

**AMATEUR BANDS RECEIVER. Model RA-1.** To cover all the Amateur Bands from 160-10 metres. Many special features, including: half-lattice crystal filter; 8 valves; signal strength "S" meter; tuned R.F. Amp. stage. Kit **£39.6.6** Assembled **£52.10.0**

**160-10M TRANSMITTER. Model DX-100U.** Careful design has achieved high performance and stability. Completely self-contained. Kit **£79.10.0** Assembled **£104.15.0**

**COMMUNICATIONS TYPE RECEIVER. Model RG-1.** A high performance, low cost receiver for the discriminating listener. Frequency coverage: 600 kc/s-1.5 Mc/s and 1.7 Mc/s-32 Mc/s. Kit **£39.16.0** Assembled **£53.0.0**

**REFLECTED POWER METER and SWR BRIDGE. Model HM-11U.** Indicates reliably, but inexpensively, whether the RF power output of your TX is being transferred efficiently to radiating antenna. Kit **£8.5.0** Assembled **£10.10.0**



**GC-1U**

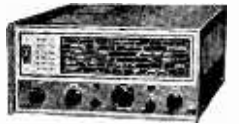

**RG-1**



**HM-11U**

### OUTSTANDING "AMATEUR" EQUIPMENT

A wide range of American Amateur SSB equipment is now available in the U.K. Why not send for full details of range, for example:

**FILTER TYPE SSB TRANSCEIVERS.**  
Models for 80, 40 or 20 metre bands.  
Model **HW-12** (80M) **£66.0.0** each kit.  
Model **HW-22** (40M) price inc. duty, etc.  
Model **HW-32** (20M)



**80M Transceiver  
HW-12**

Without obligation please send me  
**FREE BRITISH HEATHKIT CATALOGUE** (Tick here)  
**FULL DETAILS OF MODEL(S)**.....  
(Please write in BLOCK CAPITALS)

**NAME** .....

**ADDRESS** .....

**DEPT. RC.4**

# BOOKS

## NEW TITLES FROM

# FOULSHAM-SAMS

JANUARY - APRIL

- ABC'S OF ELECTRONIC ORGANS**  
by Norman H. Crowhurst Demy 8vo 96 pages 16/- Net
- ELECTRIC GUITAR AMPLIFIER HANDBOOK**  
by Jack Darr Demy 8vo 144 pages 24/- Net
- MICROWAVE PRIMER**  
by Albert Camps and Joseph A. Markum, Jr.  
Demy 8vo 192 pages 30/- Net
- PRACTICAL TRANSISTOR SERVICING**  
New Revised Edition  
by W. C. Caldwell Demy 8vo 192 pages 24/- Net
- SCIENCE PROJECTS IN ELECTRICITY**  
by Edward M. Noll Demy 8vo 144 pages 24/- Net
- ABC'S OF MICROWAVES**  
by H. Charles Woodruff Demy 8vo 96 pages 16/- Net
- 101 WAYS TO USE YOUR COLOUR T.V. TEST EQUIPMENT**  
by Robert G. Middleton Demy 8vo 144 pages 24/- Net
- TRANSISTOR RADIO SERVICING MADE EASY**  
New Revised Edition  
by Wayne Lemons Demy 8vo 144 pages 20/- Net
- T.V. SERVICING GUIDE**  
by Leslie D. Deane and Calvin C. Young, Jr.  
Size 11" x 8 1/2" 132 pages 22/- Net
- ABC'S OF SILICON CONTROLLED RECTIFIERS**  
by Allan Lytel Demy 8vo 128 pages 16/- Net
- HOW TO BUILD PROXIMITY DETECTORS AND METAL LOCATORS**  
by John Potter Shields Demy 8vo 128 pages 20/- Net
- KNOW YOUR SIGNAL GENERATORS**  
by Robert G. Middleton Demy 8vo 144 pages 20/- Net
- T.V. DIAGNOSIS AND REPAIR**  
by The PF REPORTER Editorial Staff  
Demy 8vo 96 pages 13/6 Net
- BENCH SERVICING MADE EASY**  
by Robert G. Middleton Demy 8vo 160 pages 24/- Net
- COLOUR T.V. SERVICING GUIDE**  
by Robert G. Middleton Demy 8vo 112 pages 28/- Net
- KNOW YOUR SQUARE-WAVE AND PULSE GENERATORS**  
by Robert G. Middleton Demy 8vo 144 pages 21/- Net
- TRANSISTOR ETCHED-CIRCUIT PROJECTS**  
by James Kyle Demy 8vo 160 pages 24/- Net
- T.V. TROUBLESHOOTER'S REFERENCE HANDBOOK**  
by S. Hoberman Demy 8vo 128 pages 24/- Net

Recently Published

- DESIGN AND OPERATION OF REGULATED POWER SUPPLIES**  
by Irving M. Gottlieb Demy 8vo 112 pages 24/- Net
- COLOUR TELEVISION SERVICING MADE EASY**  
by Wayne Lemons and Carl Babcoke Demy 8vo 192 pages 25/- Net
- ACOUSTICAL TESTS AND MEASUREMENTS**  
by Don Davis Demy 8vo 192 pages 30/- Net
- 101 MORE WAYS TO USE YOUR VOM & VTVM**  
by Robert G. Middleton Demy 8vo 128 pages 20/- Net
- 101 WAYS TO USE YOUR SWEEP GENERATOR**  
by Robert G. Middleton Demy 8vo 144 pages 20/- Net

from Booksellers or, plus 8d. postage from the Publishers.

Write for complete catalogue of over 100 titles.

**FOULSHAM-SAMS**  
**TECHNICAL BOOKS**

Dept. CRC, Yeovil Road, Slough, Bucks, England



### FIRST QUALITY PVC TAPE

5 1/2" Std. 850ft	9/-	5" L.P. 850ft	10/6
7" Std. 1200ft	11/6	3" T.P. 600ft	10/6
3" L.P. 240ft	4/-	5" T.P. 1800ft	25/6
5 1/2" L.P. 1200ft	11/6	5 1/2" T.P. 2400ft	32/6
7" L.P. 1800ft	18/6	7" T.P. 3600ft	42/6

P. & P. on each 1/6, 4 or more post free.

### CYLDON U.H.F. TUNER



complete with PC.88 and PC.86 Valves. Full variable tuning. New and unused. Size 4 1/2" x 5 1/2" x 1 1/2". Complete with circuit diagram. 35/- plus 2/6 P. & P.

### 3 to 4 WATT AMPLIFIER KIT



comprising chassis 8 1/2" x 2 1/2" x 1", Double wound main transformer, output transformer, volume and tone controls, resistors, condensers, etc. 6V6 ECC81 and metal rectifier. Circuit 1/6, free with kit. 29/6, plus 4/6 P. & P.

### 8-watt 5-valve PUSH-PULL AMPLIFIER & METAL RECTIFIER

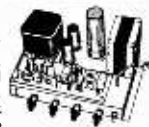

Size: 9" x 6" x 1 1/2". A.C. Mains 200-250V 5 valves. For use with Std. or L.P. records, musical instruments, all makes of pick-ups and mikes. Output 8 watts at 5 per cent total distortion. Separate bass and treble lift controls. Two inputs, with controls, for gram. and mike. Output Transformer tapped for 3 and 15 ohms speech coils. Built and tested. £3.19.6. P. & P. 10/-.

### MUSETTE 6-Transistor Superhet Portable Radio

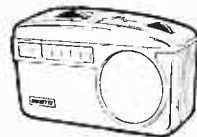

★ 2 1/2" Speaker. ★ Output 200mw. ★ Plastic Cabinet in red, size 4 1/2" x 3" x 1 1/2", and gold speaker louvre. ★ Horizontal Tuning Scale. ★ Internal Aerial. ★ IF 460 Kc/s. ★ All components and Tuning Assembly mounted on printed board. ★ Operated from PP3 Battery. ★ Full instructions and point-to-point wiring diagram. ★ Printed Circuit. ★ Medium and long waves. Price 39/6d P. & P. 3/6 inc. carrying strap. Circuit Diagram 2/6—free with parts.

### TRANSISTORISED SIGNAL GENERATOR



Size 5 1/2" x 3 1/2" x 1 1/2". For IF and RF alignment and AF output, 700 c/s frequency coverage 460 Kc/s to 2 Mc/s in switched frequencies. Ideal for alignment to our Elegant Seven and Musette. Built and tested. 39/6. P. & P. 3/6.

**POWER SUPPLY KIT** to purchasers of Elegant Seven parts, incorporating mains transformer, etc. A.C. mains 200-250V. Output 9V 50mA. 7/6d. extra.

### 'ELEGANT SEVEN' Mk. II

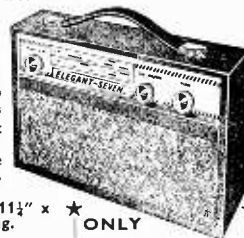

Combined Portable and Car Radio  
The Radio with the "Star" Features  
★ 7-transistor superhet. Output 350mW.  
★ Wooden cabinet, fitted handle with silver coloured fittings. Size 12 1/2" x 8 1/2" x 3 1/2".  
★ Horizontal tuning scale, size 11 1/2" x 2 1/2" in silver and black lettering.  
★ All stations clearly marked.  
★ Ferrite-rod internal aerial.  
★ I.F. Neutralisation on each stage. 460 kc/s.  
★ D.C. coupled output stage with separate A.C. negative feed back.  
★ All components, ferrite rod and tuning assembly mounted on printed board. ★ Operated from PP9 battery. ★ Full comprehensive instructions and point-to-point wiring diagrams. ★ Printed circuit board, back printed with all component values. ★ Fully tunable over medium and long waveband. ★ Car aerial socket. ★ Full after-sale service. 4" SPEAKER.  
Parts list and circuit diagram 2/6, FREE with parts.

ONLY  
**£4.4.0**  
Plus 6/6 Post & Packing

Shop Hours 9 a.m.-6 p.m. Early Closing Wednesday  
Goods not despatched outside U.K. Terms C.W.O.  
All enquiries Stamped Addressed Envelope.

**RADIO & TV COMPONENTS (ACTON) LTD.**  
21F High St., Acton, London, W.3

# SINCLAIR MICRO FM

COMBINED POCKET-SIZE FM TUNER/RECEIVER

SEVEN  
TRANSISTOR  
SUPERHET  
FM WITH  
2 OUTPUTS

*The only design of its kind in the world*

For far less money and trouble you can enjoy building and using the most advanced FM design in the world when you buy the Sinclair Micro FM. This fully fledged 7 transistor, 2 diode FM superhet has original features that ensure superb audio quality and great sensitivity together with utmost ease of assembly. There are two separate output sockets—an exclusive Sinclair feature which enables you to use your Micro FM as a tuner and an independent pocket size portable receiver whenever you wish. This wonderful set is as outstanding in appearance as in performance. Many other excellent features are included in the Micro-FM to make building an FM set easy for any constructor. Best of all, it brings first-class performance with a saving of pounds.

- ★ Size: 2½" x 1½" x ¾"
- ★ Powerful A.F.C.
- ★ Pulse counting discriminator
- ★ Low I.F. eliminates alignment problems
- ★ Tunes from 88 to 108 Mc/s
- ★ Audio response: 10 to 20,000 c/s ±1dB
- ★ Signal to Noise Ratio: 30dB at 30 microvolts
- ★ Operates from standard 9V battery, self-contained
- ★ Plastic case with brushed and polished aluminium front and spun aluminium tuning dial

Complete kit inc. telescopic aerial, case, ear-piece, and instructions **£5.19.6**



KITS EVERY CONSTRUCTOR WILL BE PROUD TO BUILD

SAVE 19/- By buying Micro FM and Z.12 together. Usual price £10.9.0. Send for Pack 'A' **£9.10.0**

# SINCLAIR Z.12

COMBINED 12 WATT AMPLIFIER AND PRE-AMP

*The ultimate in power, quality and size*



- ★ Class "B" ultra-linear output
- ★ Response 15-50,000 c/s ±1dB
- ★ Output 12W r.m.s. continuous sine wave (24W peak), 15W r.m.s. music power (30W peak)
- ★ Output impedance—suitable for 3, 7.5 or 15Ω.
- Two 3Ω speakers may be used in parallel
- ★ Input—2mV into 2kΩ
- ★ Signal to noise ratio—better than 60dB
- ★ Quiescent current consumption—15mA
- ★ Power requirements—from 6 to 20V d.c.

Never has such power and quality been obtained from so compact an amplifier. Uses 8 special H.F. transistors. May be operated at any voltage from 6-20V d.c. and the output fed directly into any load from 1.5 to 15Ω. Supplied ready built, tested and guaranteed together with manual showing all types of suitable tone and volume control circuits.

SINCLAIR P.Z.3. A new transistorized power pack for Z.12. Exceptional smoothing **79/6**

SAVE 11/- By buying 2 Z.12s together. Send for Pack 'C' **£8.8.0**

IDEAL FOR 12V OPERATION

3" x 1½" x 1⅓"  
12 WATTS R.M.S. (24W PEAK)

## SINCLAIR MICRO-6

The smallest set in the world



For power, selectivity and quality, this amazing six stage M.W. receiver is unequalled. 2 stages R.F. amplification, double diode detector, 3 stage A.F. amplifier, A.G.C. etc. Complete with self-contained aerial in white, gold and black case, size 1½" x 1⅓" x 1½". Plays anywhere. Very easy to build. Complete kit of parts with ear-piece and instructions. **59/6**

MALLORY MERCURY CELL 2M.312 (2 required) each 1s. 11d.

SAVE 9/- By buying Micro-6 and Z.12 Amplifier. Usual price £7.9.0. Send for Pack 'B' **£7.0.0**

FULL SERVICE FACILITIES AVAILABLE TO SINCLAIR CUSTOMERS  
**GUARANTEE** If you are not completely satisfied when you receive your purchase from us, your money will be refunded at once in full and without question.

SINCLAIR RADIONICS LTD., 22 NEWMARKET ROAD, CAMBRIDGE

Please send  
.....  
.....  
.....  
for which I enclose cash/cheque/money order value £.....s.....d.

NAME  
ADDRESS

RC4

**SINCLAIR**  
**SINCLAIR RADIONICS LTD**  
22 NEWMARKET ROAD, CAMBRIDGE  
Telephone 52731

# Scottish Insurance Corporation Ltd

38 EASTCHEAP · LONDON · EC3



## TELEVISION SETS, RECEIVERS AND TRANSMITTERS

Television Sets, Receivers and Short Wave Transmitters are expensive to acquire and you no doubt highly prize your installation. Apart from the value of your Set, you might be held responsible should injury be caused by a fault in the Set, or injury or damage by your Aerial collapsing.

A "Scottish" special policy for Television Sets, Receivers and Short Wave Transmitters provides the following cover:

- (a) Loss or damage to installation (including in the case of Television Sets the Cathode Ray Tube) by Fire, Explosion, Lightning, Theft or Accidental External Means at any private dwelling-house.
- (b) (i) Legal Liability for bodily injury to Third Parties or damage to their property arising out of the breakage or collapse of the Aerial Fittings or Mast, or through any defect in the Set. Indemnity £10,000 any one accident.
- (ii) Damage to your property or that of your landlord arising out of the breakage or collapse of the Aerial Fittings or Mast, but not exceeding £500.

The cost of Cover (a) is 5/- a year for Sets worth £50 or less, and for Sets valued at more than £50 the cost is in proportion. Cover (b) (i) and (ii) costs only 2/6 a year if taken with Cover (a), or 5/- if taken alone.

Why not BE PRUDENT AND INSURE your installation—it is well worth while AT THE VERY LOW COST INVOLVED. If you write to the Corporation's Office a proposal will be submitted for completion.

---

Write for full details, quoting reference 5304, to:—

**THE MANAGER**  
**SCOTTISH INSURANCE CORPORATION LTD.,**  
**38 EASTCHEAP, LONDON E.C.3**

---



# UNIQUE OPPORTUNITY

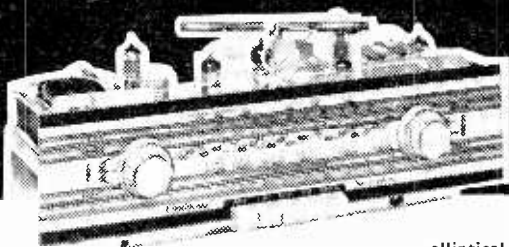

## TO PURCHASE STEREOPHONIC RADIOGRAM CHASSIS

Magnificent Stereophonic Radiogram Chassis complete with two 10" elliptical loudspeakers, plus a Mono/Stereo 4-speed automatic record changer.

**Only £29.19.6**

- ★ Easily fitted
- ★ No soldering or Technical knowledge necessary
- ★ Fits almost any cabinet with minimum trouble
- ★ Modernises your old radiogram
- ★ Built-in ferrite rod aerial
- ★ Piano key switching
- ★ Luxembourg and Caroline received at full strength
- ★ Listen to U.S.A., Russia, Africa, Canada and even Australia
- ★ Unique Lewis Radio 365 day guarantee, even on all the valves
- ★ All British make

**SPECIAL** terms available of **£7.10.0** deposit followed by 18 monthly payments of **£1.9.1** (total H.P. **£33.13.6**) + postage and packing 15/- extra.

**INDIVIDUAL CABINETS SUPPLIED ON REQUEST**

Send your cheque or P.O. today for **£8.5.0** while stocks last to Dept. RC.1

**LEWIS radio**

LEWIS RADIO, 100, CHASE SIDE, SOUTHGATE  
LONDON, N.14. Telephone: PAL 3733/9666

THE WORD

**MAXI-Q**

IS THE REGISTERED  
TRADE MARK

OF DENCO (CLACTON) LIMITED  
IT IS ALSO A GUARANTEE OF  
WORKMANSHIP AND  
TECHNICAL PERFORMANCE

OUR RANGE OF PRODUCTS IS SO GREAT THAT WE NOW HAVE TO REQUEST THE AMOUNT OF 2s. 0d. FOR OUR GENERAL CATALOGUE AND TO SAVE YOU POSTAL ORDER POUNDAGE CHARGE WE REQUEST SEND 2s. 0d. IN STAMPS.

IN RESPONSE TO CONTINUOUS DEMAND we have commenced production of Self-Contained Multiplex Decoder Unit, aligned ready for immediate use, that will convert your two receivers—tuner and two amplifiers—tuner and stereo amplifier or stereo receiver without Multiplex provision to a complete B.B.C. Stereo Broadcast Reception Unit. Price £8.0.0, post paid. Technical Publication MD1, 4s. 0d., post paid.

IFT.11/465 kc/s centre tapped transformer for use in crystal filter circuits,  $1\frac{7}{8}$ " x  $\frac{13}{16}$ " square. 10s. 6d. plus 8d. post.  
IFT.18/465 kc/s and 1.6 Mc/s Double Tuned transistor transformer  $1\frac{1}{2}$ " x  $\frac{1}{2}$ " square. 10s. 6d., plus 8d. post.

Please send S.A.E. with all enquiries. General Catalogue 2s. 0d.

**DENCO (CLACTON) LTD.**

(DEPT. R.C.)

357/9 OLD ROAD, CLACTON-ON-SEA, ESSEX

# A Tale of Two Citizens

(OR HOW TO AVOID FRETWORK)

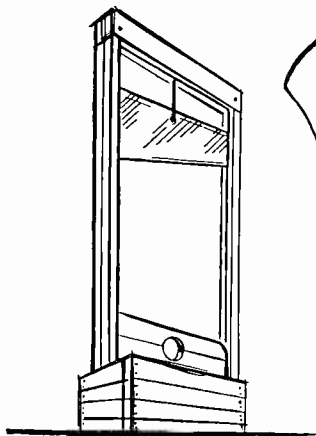

*All characters are entirely fictitious  
... we just don't know anybody  
named 'A' or 'B'!*

## This is citizen A . . .

He has just read an excellent article in a very well-known radio magazine (for title see front cover) and has decided to build the article described. He has prepared the list of components required. Now his troubles begin . . . first, where to buy the components! He knows that shop X stocks 1% tolerance resistors, but not 1% tolerance silver mica condensers. Shop Y has 1% tolerance silver mica condensers, but not miniature transistor transformers. Shop Z has the transformers but not the other two items! Should citizen A call on X, Y and Z? This will take much of his spare time, to say nothing of the fares! Should he write to X, Y, and Z? Trouble again—he doesn't know the cost of each item and he will have to pay three lots of postage. Citizen A decides to take up fretwork!!

## This is citizen B . . .

He has just read the same article as A. He too has prepared his list of components. But B has a Home Radio Catalogue! In his catalogue is an Order Form which he quickly fills in with the aid of the special price supplement supplied. Postage is no problem, because Home Radio charge a flat rate of 2/6 per parcel—whether for a resistor weighing one ounce or a transformer weighing 20 lb. Admittedly, this is tough on citizens ordering one resistor! The answer is to plan ahead. Why pay 10/- postage and packing for four small orders when you can get one large order for 2/6 p and p? So wise citizen B sends off his order and money, happy in the knowledge that the goods he has ordered will be despatched to him, carefully packed, within the next two or three days. He throws away his fretwork saw, and eagerly awaits the postman's knock!

Why not join the many thousands of more-than-satisfied Home Radio customers? Our famous Components Catalogue costs 7/6 plus 1/6 p. and p. Every catalogue contains 5 coupons, each worth 1/- when used as directed. Send the attached coupon today, with your cheque or P.O. for 9/-. "It is a far better thing than you have ever done before".

Please write your Name and Address in block capitals

Name .....

Address .....

Home Radio Ltd., Dept. RC, 187 London Rd., Mitcham, Surrey



Incorporating THE RADIO AMATEUR

## APRIL 1966

Vol. 19, No. 9  
Published Monthly  
(1st of month)

*Editorial and  
Advertising Offices*

57 MAIDA VALE LONDON W9

*Telephone*  
CUNningham 6141

*Telegrams*  
Databux, London

First Published  
1947

Receiver Circuit for Caravans, <i>by Sir Douglas Hall, K.C.M.G., M.A.(Oxon)</i>	538
Can Anyone Help?	540
Variable Voltage Regulated Supply with Excess Current Protection (Suggested Circuit No. 185), <i>by G. A. French</i>	541
Economy Parking Light Controller, <i>by F. C. Judd, A.Inst.E</i>	544
Single Transistor Audio Oscillator, <i>by J. S. Brown</i>	546
News and Comment	548
Vacuum or Solid State?, <i>by R. S. Thornton</i>	550
Home or Office Intercom System, <i>by P. J. Best</i>	552
Recent Publications	553
The "Unity" Light Programme Receiver, <i>by D. B. Pitt</i>	554
Club Events	556
Finding the Velocity of Sound in Air Experimentally, <i>by H. Lewis</i>	557
Automatic Gramophone Cut-Out Device, <i>by C. J. Collister</i>	559
Solid State Microwave Oscillators	561
In Your Workshop	562
New Photon Coupled Devices, <i>by J. B. Dance, M.Sc.</i>	571
Transistorised AC Millivoltmeter, Part 1, <i>by H. Smith and D. L. Woolley, B.Sc. (Cover Feature)</i>	572
Understanding Radio, <i>by W. G. Morley</i>	577
Amplifiers for Transistor Voltmeters, <i>by C. Crosbie</i>	582
Radio Topics, <i>by Recorder</i>	584

© Data Publications Ltd., 1966. Contents may only be reproduced after obtaining prior permission from the Editor. Short abstracts or references are allowable provided acknowledgement of source is given.

Annual Subscription 33s. (U.S.A. and Canada \$5) including postage. Remittances should be made payable to "Data Publications Ltd". Overseas readers please pay by cheque or International Money Order.

Published in Great Britain by the Proprietors and Publishers Data Publications Ltd. 57 Maida Vale London W9  
Printed by A. Quick & Co. (Printers) Ltd. Clacton-on-Sea England

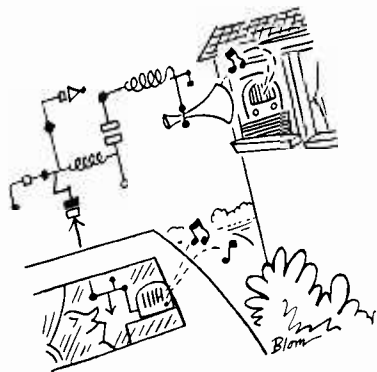

# Receiver Circuit for Caravans

By Sir Douglas Hall

K.C.M.G., M.A. (Oxon)

*Just the job for a caravan is this sensitive medium and long wave receiver whose only power supply requirement is 100mA from a 12 volt car battery! Our contributor displays his customary ingenuity in producing yet another cleverly designed circuit which offers maximum performance from a minimum of components*

**T**HIS ARTICLE DESCRIBES A SIMPLE hybrid circuit which will give good results on medium and long waves from a 12 volt supply and a normal car-type aerial. Current consumption is only of the order of 0.1 amp so that the receiver may be used for long periods without running down the battery. It is particularly suitable for use in a caravan when a 12 volt supply is available from the car battery. It can also be used as a car radio when the car is stationary, but the output is not sufficiently high for use on the open road except in a quiet motor car. It is ample for occasions when the car is stationary.

## The Circuit

The circuit is shown in Fig. 1. TR<sub>1</sub> is a common emitter high frequency amplifier with the input untuned. A good transistor will give higher amplification, in these circumstances, than a valve, as its input impedance is low and it is reasonably well matched to the fairly low impedance of the aerial-earth system. No extra selectivity is offered by an untuned stage, but with a circuit designed to be used with an aerial only about 3 or 4 feet long, and incorporating a highly selective radio frequency transformer for medium waves, this is of little importance.

The tuning coil arrangements are unusual. The coil unit consists of L<sub>1</sub>, L<sub>2</sub> and L<sub>3</sub>. These are wound to the dimensions shown in Fig. 2. L<sub>1</sub>

has 300 turns of 38 s.w.g. enamelled wire wound in a single pile and with a tapping at 100 turns from the end remote from L<sub>2</sub>. L<sub>2</sub> and L<sub>3</sub> use 32 s.w.g. wire. L<sub>2</sub> has 50 turns, close wound, and L<sub>3</sub> has 25 turns wound in a narrow pile. The coils are wound on a sleeve made of "contact" or similar paper-backed adhesive plastic on a piece of 3/8 in ferrite rod, 3 in long. Coverage will be from about 190 to 550 metres on the medium waveband, and from about 1,250 metres to well over 2,000 on the long waveband. Turns should not be removed from L<sub>1</sub> in order to lower the wavelength coverage as this will result in L<sub>1</sub> resonating with its self-capacitance within the medium waveband, and will render the receiver inoperative on the long wavelength end of that band.

If Fig. 1 is studied it will be seen that, with S<sub>1</sub>(a), (b), (c) in the lower position, L<sub>1</sub> forms the collector load for TR<sub>1</sub> and couples, on the "large primary" principle, to L<sub>2</sub>, which is the medium wave tuning coil.<sup>1</sup> This arrangement provides good selectivity and uniform coupling throughout the band. L<sub>3</sub> is the reaction coil for medium waves. The earthy end

of L<sub>1</sub> is taken to the positive filament pin of V<sub>2</sub> to reduce the voltage available for TR<sub>1</sub> to about 9 volts. L<sub>2</sub> and L<sub>3</sub> have their earthy ends taken to positive, and not negative, battery line, to facilitate the special reaction-cum-volume control method used. C<sub>3</sub> completes the r.f. circuit and provides a short r.f. path for VC<sub>1</sub>.

With S<sub>1</sub> (a) (b) (c) in the upper position, L<sub>1</sub> is still the collector load for TR<sub>1</sub>, but is now also the long wave tuning coil. The collector is tapped into it to reduce damping by TR<sub>1</sub>. The reaction coil is now L<sub>2</sub>.

V<sub>1</sub> and V<sub>2</sub> are pentode output valves of a type which are frequently advertised in this magazine. Filament voltage is supplied via R<sub>10</sub>.

V<sub>1</sub> is a leaky-grid detector. It will be found to work very efficiently with the small h.t. voltage available for it. R.F. for reaction purposes is taken from the anode through C<sub>5</sub> to the slider of VR<sub>1</sub>. As the slider of VR<sub>1</sub> is moved in an upwards direction, the part of the track between C<sub>5</sub> and the reaction coil is reduced and reaction increases. At the same time the d.c. voltage available for V<sub>1</sub> increases, since VR<sub>1</sub> is across the battery. At the minimum position, V<sub>1</sub> is deprived of anode and screen-grid voltage, and no signals are passed. As may be seen, V<sub>1</sub> is a triode so far as reaction is concerned, its anode and screen-grid being joined together for r.f. signals. It will be found that a

<sup>1</sup> It is conventional practice, on medium and long waves, for an aerial coupling coil to have a considerably larger inductance than the tuned coil. The aerial coupling coil, in company with the aerial-earth capacitance, then becomes broadly resonant below the low frequency end of the band covered, thereby boosting sensitivity at this end.—EDITOR.

## Components List

### Resistors

(All fixed resistors  $\frac{1}{4}$  watt 10% unless otherwise stated)

- R<sub>1</sub> 2.7k $\Omega$
- R<sub>2</sub> 47k $\Omega$
- R<sub>3</sub> 1.2k $\Omega$
- R<sub>4</sub> 2.2M $\Omega$
- R<sub>5</sub> 220k $\Omega$
- R<sub>6</sub> 1M $\Omega$
- R<sub>7</sub> 150k $\Omega$
- R<sub>8</sub> 1M $\Omega$
- R<sub>9</sub> 330 $\Omega$
- R<sub>10</sub> 100 $\Omega$ , 2 watts, 5%
- VR<sub>1</sub> 25k $\Omega$  potentiometer, linear track
- VR<sub>2</sub> 5k $\Omega$  potentiometer, pre-set

### Capacitors

- C<sub>1</sub> 0.01 $\mu$ F, paper
- C<sub>2</sub> 0.1 $\mu$ F, paper
- C<sub>3</sub> 0.01 $\mu$ F, paper
- C<sub>4</sub> 100pF, silver-mica or ceramic
- C<sub>5</sub> 330pF, silver-mica or ceramic
- C<sub>6</sub> 0.01 $\mu$ F, paper
- C<sub>7</sub> 27pF, silver-mica or ceramic
- C<sub>8</sub> 1,000pF, paper or ceramic
- C<sub>9</sub> 100 $\mu$ F, electrolytic, 12V wkg.
- VC<sub>1</sub> 500pF variable, solid dielectric

### Inductors

- L<sub>1,2,3</sub> Coil unit (see text)
- L<sub>4</sub> 2.5mH choke, Repanco type CH1
- L<sub>5</sub> Primary (red and blue leads) of Repanco transformer type TT53
- T<sub>1</sub> Output transformer, Repanco type TT5

### Valves

- V<sub>1,2</sub> 3Q5GT (DL33)

### Transistors

- TR<sub>1</sub> MAT101 or MAT121
- TR<sub>2</sub> G.E.C. S5 or S6 (see text)

### Switches

- S<sub>1</sub> (a), (b), (c), 3-pole 2-way
- S<sub>2</sub> s.p.s.t. (may be ganged with VR<sub>1</sub>)

### Loudspeaker

- 3 $\Omega$  impedance

### Miscellaneous

- 2 International Octal valveholders
- Ferrite rod, 3 x  $\frac{3}{8}$  in
- Cabinet, etc.

smooth control from zero to oscillation point results.

L<sub>4</sub> is an anti-breakthrough choke to prevent any possibility of a powerful medium wave station forcing its way through on to the long waveband.

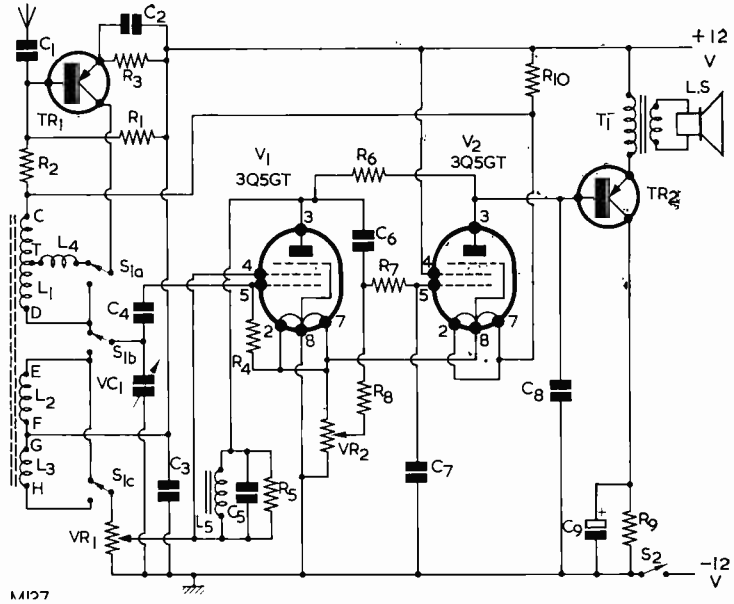

Fig. 1. The circuit of the receiver. Switches S<sub>1</sub>(a), S<sub>1</sub>(b), S<sub>1</sub>(c), are ganged together to form the wavechange switch

The low frequency anode load is L<sub>5</sub>, which is the primary of an inexpensive transformer designed for coupling a crystal pick-up to the input of a common emitter amplifier. The winding has a very high inductance, this being well maintained with the small current passing through it in the present circuit. It is shunted by a 220k $\Omega$  resistor, R<sub>5</sub>, to prevent threshold howling. Far greater amplification is possible by this method than by using resistance coupling, especially when only 12 volts are available for V<sub>1</sub>.

The amplified signal appearing across L<sub>5</sub> is fed to the grid of V<sub>2</sub> by means of C<sub>6</sub>. R<sub>7</sub> and C<sub>7</sub> maintain stability. Negative feedback is provided by R<sub>6</sub>.

### Valve-Transistor Coupling

The arrangements for coupling V<sub>2</sub>

to TR<sub>2</sub> involve a new circuit developed by the author. V<sub>2</sub> will have a very high output impedance. Provided it is found possible not to damp this output impedance, V<sub>2</sub> will offer a very high degree of amplification despite the limitation of less than 12 volts high tension. TR<sub>2</sub> is connected as a common collector large signal amplifier. In this configuration it is capable of providing good current amplification. No voltage amplification is offered, as there is 100% negative feedback of voltage inherent in the operation of a common collector amplifier which, incidentally, results in unusually good quality. Quite considerable voltage amplification is provided by the two pentodes so plenty of power is available from TR<sub>2</sub>. A common collector amplifier must have an output load which is

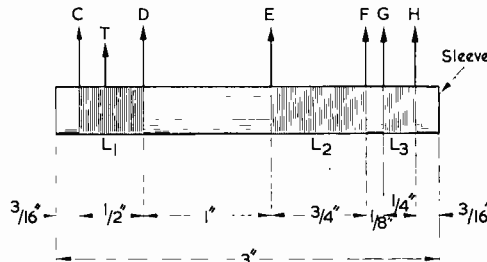

Fig. 2. Details of the coil-unit. The turns and wire required are described in the text. The letters shown correspond to those of Fig. 1

not too low, to maintain its current amplification and high input impedance which, in favourable circumstances, is similar to the output impedance of a pentode. It follows, therefore, that direct coupling from a pentode valve to a common collector transistor power amplifier is both practicable and highly efficient, provided a transistor is chosen which gives satisfactory results with a base current equal to the anode current passed by the pentode.

It will be seen that the input of TR<sub>2</sub> forms the output load for V<sub>2</sub>. This is a most satisfactory load as it has a high impedance to a.c. (the signal) and a low resistance to direct current. A snag, however, remains to be overcome. Although the resistance to d.c. of V<sub>2</sub> forms the bias arm from the negative supply line to base, the path from base to the positive line remains open. There is, therefore, a state of affairs which can lead to thermal runaway, and the normal solution of a resistor between base and positive arm is ruled out as it would cause hopeless damping of the load offered to V<sub>2</sub>. The answer to the problem is to abandon any idea of current stabilisation and adopt, instead, a form of power stabilisation. That is to say, we allow the current passed by TR<sub>2</sub> to vary but arrange that any increase in current is accompanied by a corresponding decrease in voltage available, the power remaining sub-

stantially constant and within the limits allowed for the transistor. This effect is produced by R<sub>9</sub>. C<sub>9</sub> is a bypass for the signal.

TR<sub>2</sub> must be a high amplification output transistor which will tolerate 100mW and, in order not to be damaged while VR<sub>2</sub> is being adjusted, up to 30mA current. The author recommends the G.E.C. S5 or S6.<sup>2</sup> For maximum power, bearing in mind the function of R<sub>9</sub> and the impedance of the output load, TR<sub>2</sub> should pass about 10mA. For this it will require a base current of from about 50 to 150μA depending on its amplification factor. It is necessary, therefore, for V<sub>2</sub> to be set up to pass this current, and the necessary adjustment is made by VR<sub>2</sub>, which controls grid bias. If a milliammeter is available it should be inserted between T<sub>1</sub> and the positive line, and VR<sub>2</sub> adjusted so that 10mA is registered. If no milliammeter is available adjustment can be done by ear, using a powerful station and adjusting for maximum volume without distortion. If grid bias is too great, both V<sub>2</sub> and TR<sub>2</sub> will be short of current and there will be distortion. If grid bias is too small a heavy current will pass through TR<sub>2</sub> and,

<sup>2</sup> The S5 and S6 (or GET.S5 and GET.S6) transistors do not appear in the normal lists, but are available as surplus items at very low cost. The author obtained his from Lasky's Radio, 207 Edgware Road, London, W.2. A possible alternative in the present circuit would be the ACY18 or ACY21.—EDITOR.

because of R<sub>9</sub>, it will be short of voltage and again there will be distortion. R<sub>9</sub> will prevent damage to TR<sub>2</sub> whatever the setting of VR<sub>2</sub>.

#### Loudspeaker Requirements

It is recommended that a good loudspeaker be used and that it be mounted in a separate box to avoid any possibility of microphonic howling due to the large amount of audio frequency amplification.

Nothing longer than a normal car aerial should be used. Earthing is automatic through the battery. The receiver should be insulated from the metalwork of the caravan or car and may then be used whether the negative or positive side of the battery is earthed. There is some advantage in using a metal case for the receiver, since this prevents direct pick-up of a very powerful signal by the coil unit. The lead to the aerial should not be screened, since this will reduce input as a result of losses due to self-capacitance which cannot be "tuned out" with an untuned input stage. There is no need for screening, either, with a stationary engine.

The circuit will be found surprisingly sensitive. In South Devon, the Home, Light and Third programmes, together with four Continental stations, can be received in daylight at good volume, and about 30 alternative programmes are offered after dark.

## CAN ANYONE HELP?

*Requests for information are inserted in this feature free of charge, subject to space being available. Users of this service undertake to acknowledge all letters, etc., received and to reimburse all reasonable expenses incurred by correspondents. Circuits, manuals, service sheets, etc., lent by readers must be returned in good condition within a reasonable period of time*

EMI Emicorda Model 2031H.—E. G. Priestly, 6 Lynden Avenue, High Busy Lane, Windhill, Shipley, Yorks.—circuit, service manual of this tape recorder, loan or purchase, all expenses met.

\* \* \*

Cossor 1035 Oscilloscope.—B. L. Anderson, 6 Hallam Mews, Hallam Street, London, W.1—service manual or circuit diagram. Also circuit for Musi-Pak (U.S.A.) continuous background music playback machine and HMV 2314 transistor stereogram. Each will be photocopied and returned.

Oscilloscope Type 11.—R. E. Fields, 49 Torkington Road, Gatley, Cheadle, Cheshire—circuit or service manual for this ex-Air Ministry equipment (Ref. No. 10s/562).

\* \* \*

Coil.—R. K. Lloyd, Lloyd's, P.O. Box 1164, Lusaka, Zambia, Africa—details required for making the Wearite type PA2 coil (unobtainable at location). Also connections and voltages for the klystron type WL-417A.

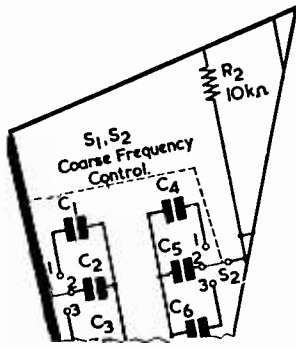

# Variable Voltage Regulated Supply with Excess Current Protection

SUGGESTED CIRCUIT No. 185

By G. A. FRENCH

**D**URING EXPERIMENTAL WORK with transistor circuits it is quite possible for unexpected results or faulty connections to cause an excessive current to be drawn from the supply. This excessive current may readily damage the power supply as well as the semiconductors in the experimental circuit itself.

At the same time it is desirable to have available, for experimental work, a power supply offering a continuously variable output voltage with reasonably good regulation. Experimental circuits whose behaviour may be unpredictable may then be fed at first from a low output voltage, this being brought up to the full voltage if initial results are satisfactory. The variable output voltage facility also, of course, allows the selection of any particular working voltage which is required.

This month's "Suggested Circuit" presents a design for a power supply unit which meets all these requirements. The unit has a variable voltage output with a maximum of about 12 volts, and it offers reasonably good regulation. What is perhaps the most important feature is that its output drops to zero if any attempt is made to draw more than a specified maximum current, the specified maximum current being selected by a switch. It is, in fact, impossible to draw more than the selected maximum current from the power unit. As will be seen later, the circuit suffers from the drawback that several high wattage resistors are required, together with a larger mains transformer than would normally be employed to supply the output voltage and current provided. However the writer feels that, for experimental and laboratory work, the disadvantages of slight extra bulk and cost which result from the

larger transformer and high wattage resistors are outweighed by the advantages in performance which are provided.

### Short-Circuit Protection

Before proceeding to the power supply unit itself, it will be helpful to consider, initially, the simple circuit shown in Fig. 1. In this diagram we have an h.t. direct voltage supply which is coupled, via a current limiting resistor, to a zener diode. An output voltage, which may be of the order of 10 volts or so, according to the diode employed, is taken from two terminals connected across the diode. This basic circuit illustrates the manner in which short-circuit protection is provided in the power supply unit to be described.

To take a numerical example of circuit functioning, let us assume that the h.t. supply voltage in Fig. 1 is 200, and that we wish to take an output of 10 volts from the output terminals. The maximum current which may flow from the output terminals is 50mA.

From Ohm's Law, we know that a resistor of 4kΩ allows a current of 50mA to flow when a voltage of 200 is applied across it, and so we give the current limiting resistor a value of 4kΩ. We next select a 10 volt zener diode capable of passing 50mA and connect this in

the zener diode position. We then apply the 200 volt h.t. supply. The zener diode stabilises the output voltage at 10, and the output voltage remains at this figure for all load currents up to slightly less than 50mA. When 50mA is closely approached, insufficient current is available for the zener diode to stabilise and the output voltage drops. When 50mA exactly is drawn, the output falls to zero because the full 200 volts from the h.t. supply is then dropped across the current limiting resistor. Even if the load presents a short-circuit to the output terminals the current which flows cannot exceed 50mA, due to the presence of the current limiting resistor.

As may be realised, any output voltage and any maximum output current may be obtained by appropriate selection of the zener diode and the current limiting resistor. Two disadvantages are that a relatively high power is dissipated in the current limiting resistor, and that the h.t. supply has to provide a high voltage at the same current as is drawn by the zener diode and the output load. It will be noted that there is a continual current in the current limiting resistor even if no output current is drawn. In the example just given, the continual current limiting resistor is due to the 190 volts (200 volts

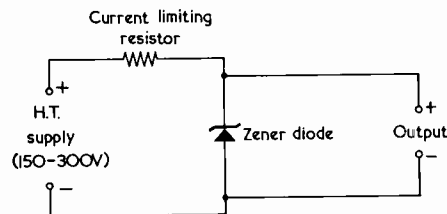

Fig. 1. A circuit which illustrates the basic current limiting principle

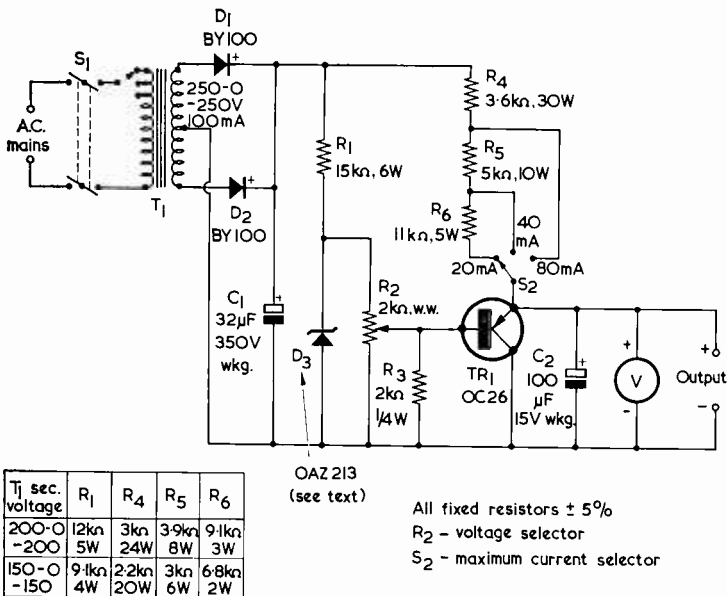

Fig. 2. The prototype circuit checked by the author. This provides a variable regulated output voltage, together with short-circuit protection. Since the output will normally be required to be "floating", no connection to chassis is shown

minus the 10 volts dropped across the zener diode) which appears across it. The voltage across the resistor rises to 200 when the output current closely approaches, and reaches, the maximum figure of 50mA. Thus, the current drawn from the h.t. supply is nearly constant, regardless of output load current.

The neat approach to power supply design illustrated in Fig. 1 is not new, and the writer first encountered it in an article in the American journal *Electronics World* by Hugh L. Moore, to whom acknowledgement is made.\* The *Electronics World* article describes a power supply in which either a 10 volt zener diode, a 20 volt zener diode or the two diodes together in series may be switched into circuit to provide outputs of 10, 20 or 30 volts. Different values of current limiting resistor may also be switched in to provide different figures for maximum output current.

Power supplies based on the circuit of Fig. 1 may be easily built by the home-constructor. The h.t. supply giving the voltage between 150 and 300 need not be well-regulated, provided that it is capable of offering the maximum output current required. The current limit-

ing resistor should have a value which causes the maximum current to flow when the output terminals are short-circuited. The zener diode must be capable of passing this maximum current continually and, in most practical cases, will need a dissipation figure higher than that offered by zener diodes in the normally-encountered OAZ200 to OAZ213 range. High power zener diodes are, however, readily available through the usual trade channels, and a suitable range is listed, for instance, in the catalogue of Henry's Radio Ltd. The power actually dissipated by the zener diode is very slightly less than the product of zener voltage and maximum current requirement.

#### Variable Voltage Output

The writer felt that the basic idea of Fig. 1 could be incorporated in a power supply which also offered a stabilised variable voltage output. This could be achieved by using, instead of the zener diode, a power transistor connected as an emitter follower and having its base coupled to a continuously variable reference voltage. A prototype was then made up to check this approach, and it was found that results were sufficiently good to merit the inclusion of its circuit in this series of articles.

The circuit of the writer's prototype

appears in Fig. 2. In this diagram the a.c. mains is applied, via on-off switch S<sub>1</sub>, to the primary of a standard mains transformer having an h.t. secondary giving 250-0-250 volts at 100mA. A full-wave rectifier circuit given by two BY100 silicon diodes and the 32µF reservoir capacitor, C<sub>1</sub>, enables a rectified voltage somewhat in excess of 250 (according to the current drawn by the rest of the circuit) to be given. This voltage is applied, via R<sub>1</sub>, to zener diode D<sub>3</sub>, which has a nominal zener voltage of 12. Voltages between zero and 12 may then be tapped off by potentiometer R<sub>2</sub>.

The slider of R<sub>2</sub> connects to the base of TR<sub>1</sub>, which is an OC26. This transistor is employed as an emitter follower with its collector connected to the high tension negative supply line. The emitter of TR<sub>1</sub> couples to the high tension positive line via whichever combination of R<sub>4</sub>, R<sub>5</sub> and R<sub>6</sub> is selected by switch S<sub>2</sub>. Since TR<sub>1</sub> functions as an emitter follower, its emitter is always slightly positive of its base, whereupon emitter voltage may be varied by adjusting potentiometer R<sub>2</sub>. The transistor now takes the place of the zener diode of Fig. 1 and a regulated voltage, whose value depends on the setting of R<sub>2</sub>, appears across it. The output voltage is then taken from the collector and emitter of the transistor, capacitor C<sub>2</sub> providing final smoothing. An optional voltmeter is also connected across the output.

Resistors R<sub>4</sub>, R<sub>5</sub> and R<sub>6</sub> perform the same function as did the current limiting resistor of Fig. 1. When S<sub>2</sub> is in the "80mA" position only R<sub>4</sub> is in circuit, and short-circuit current is limited to 80mA. In the "40mA" position, R<sub>4</sub> and R<sub>5</sub> in series are in circuit, and short-circuit current is limited to 40mA. In the "20mA" position, R<sub>4</sub>, R<sub>5</sub> and R<sub>6</sub> in series are in circuit, causing short-circuit current to be limited to 20mA. Output voltage is variable, by adjustment of R<sub>2</sub>, from slightly more than zero volts to slightly more than the voltage across D<sub>3</sub>.

Since R<sub>2</sub> is a conventional potentiometer with its consequent mechanical limitations, it is possible that, due to wear or the ingress of dirt, its slider may occasionally lose contact momentarily with the track as it is rotated. If no precaution were taken, this temporary disconnection would then break the bias circuit to the base of TR<sub>1</sub>, whereupon the emitter of this transistor would rise towards the full high tension voltage. The result would be the breakdown of



the transistor and the risk of damage to components connected to the output terminals. Resistor  $R_3$  performs the important task of preventing this eventuality. If any momentary disconnection between the slider and track occurs in  $R_2$ , resistor  $R_3$  still allows sufficient bias current to flow to keep the emitter of  $TR_1$  at a safe value. The lowest current gain figure quoted for an OC26 is 20, whereupon a base current of approximately 4mA would allow an emitter current of 80mA to flow.  $R_3$  has a value of 2k $\Omega$ , and a base current of 4mA would cause a voltage of 8 to appear across it. Thus, even with  $S_2$  set to the "80mA" position and an OC26 on the bottom gain figure in the  $TR_1$  position, a momentary disconnection of the slider of  $R_2$  could not result in a collector-emitter voltage in excess of about 8. Whilst the presence of  $R_3$  prevents damage to  $TR_1$ , it would still be wise to employ a good-quality component in the  $R_2$  position. It should be added that the writer experienced no difficulty in practice with intermittent contact in  $R_2$ , despite the fact that the component used here had seen a considerable amount of service in other equipment.

The presence of  $R_3$  results in a non-linear relationship between output voltage and spindle rotation in  $R_2$ . However, output voltage control is quite smooth and there is no difficulty in adjustment.

#### Further Points

The prototype employed a mains transformer having a secondary current of 100mA, this component being immediately to hand when the circuit was tried out. Some of the rectified high tension current has to flow through the circuit given by the zener diode and  $R_2$ , and the available output current becomes reduced in consequence. Bearing in mind the minimum gain figure of 20 for an OC26, it was considered that at least 5mA should flow through the track of  $R_2$ . It is also desirable to pass at least several milliamps through the zener diode to bring it well onto the flat part of its curve. The compromise eventually arrived at resulted in the choice of component values shown in Fig. 2. With these values, about 16mA flows through  $R_1$ , about 12mA passing through  $R_2$  and  $R_3$  when the slider of  $R_2$  is at the top of its track. This left some 84mA available for the emitter of  $TR_1$ , whereupon the maximum current offered by the power supply unit can be made a nominal 80mA.

The OAZ213 has a spread in

zener voltage of 9.4 to 15.3 at 5mA and it may be desirable to select a diode whose zener voltage is in the region of 12 to 13 volts. The diode employed in the prototype had a zener voltage of approximately 11.5, and this prevented the output voltage from rising to a full 12 volts when the slider of  $R_2$  was at the top of its track. If an alternative zener diode is employed its zener voltage should not exceed 14, since higher voltages could bring the OC26 close to its maximum rated operating conditions.

The values for  $R_4$ ,  $R_5$  and  $R_6$  were found empirically, as the rectified voltage across  $C_1$  has relatively poor regulation. It is a consequence of this poor regulation that these three resistors do not bear simple numerical ratios with each other, despite the fact that the maximum currents selected by  $S_2$  are in the ratio 20 : 40 : 80. It is possible that other mains transformers, because of differing internal resistances, may offer slightly different voltages across  $C_1$ . Because of this,  $R_4$ ,  $R_5$  and  $R_6$  may require slight adjustment in value. Short-circuit current is measured, incidentally, by connecting a milliammeter with an appropriate f.s.d. across the output terminals.

It is possible to employ transformers having lower voltage secondaries in the  $T_1$  position, and the table in Fig. 2 shows suggested values for  $R_1$ ,  $R_4$ ,  $R_5$  and  $R_6$  for transformers having secondaries of 200-0-200 and 150-0-150 volts at 100mA. The values are calculated, and those for  $R_4$ ,  $R_5$  and  $R_6$  may need adjustment in practice.

The 80mA output current offered by the 100mA transformer in the circuit of Fig. 2 should be adequate for most transistor experimental work. Higher output currents can be given if a transformer having a

higher secondary current rating is employed, the values of  $R_4$ ,  $R_5$  and  $R_6$  being adjusted accordingly. An alternative method of energising the zener diode and potentiometer is discussed at the end of this article, whereupon the transformer secondary current saved can be added to that available at the output. This alternative method of running the zener diode section should also be used if output currents in excess of 120mA are to be employed.

Some constructors may require that  $S_2$  select less or more than three maximum currents, or they may require different maximum current figures. The requisite changes to the switch and current limiting resistor values can, of course, be readily visualised.

The OC26 is well under-run in the present application, but it might still be wise to mount it on a small heat sink. Other power p.n.p. transistors having suitable voltage and current ratings could also be used and improved performance (from the point of view of regulation) would result if the transistor chosen has a gain higher than that offered by the OC26.

Fig. 3 shows regulation curves obtained with the prototype, with  $S_2$  set to the "80mA" position. The top curve is given with  $R_2$  slider at the upper end of its track, whereupon the output voltage at zero current is 11.6. (As was mentioned earlier, the OAZ213 employed in the prototype stabilised at less than 12 volts). This curve shows quite good regulation up to 75mA, the output dropping only to 11.5 volts at this current. The curve continues straight for a short distance after 75mA, after which it breaks sharply into the slope given by series resistance on its own, dropping to zero volts at 80mA. Regulation resistance up to 75mA (given by the

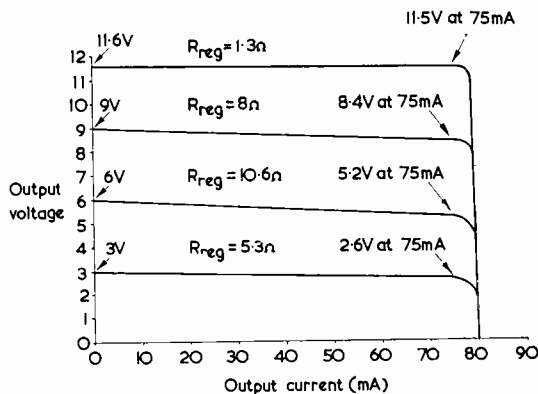

Fig. 3. Regulation curves obtained with the prototype circuit of Fig. 2

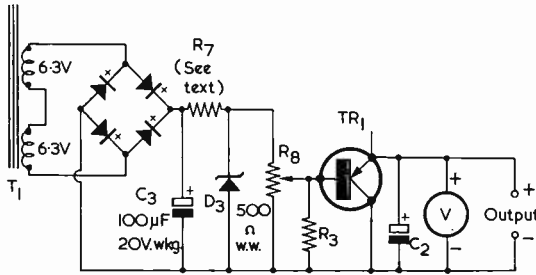

Fig. 4. A suggested alternative method of supplying the zener diode and potentiometer circuit. This enables a higher output current with improved regulation to be achieved.  $R_1$  and  $R_2$  of Fig. 2 are not required when the circuit shown here is used

drop of 0.1 volts divided by 75mA) is 1.3Ω.

The second curve applies to the case where  $R_2$  is set to give an output of 9 volts at zero current. The regulation resistance is, this time, 8Ω, and there is the same dramatic change to the current limiting slope as 80mA is approached. The next curve commences at 6 volts, and shows a regulation resistance of 10.6Ω, whilst the bottom curve starts at 3 volts and exhibits a regulation resistance of 5.3Ω. The last two curves also clearly illustrate the current limiting action. A similar class of performance is given when  $S_2$  is set to the "40mA" and "20mA" positions.

The regulation shown by all the curves in Fig. 3 should be adequate for most normal experimental work with transistors. The poorer regula-

tion at voltages below that which occurs when  $R_2$  is at the top of its track is patently due to the resistance inserted in the base bias circuit by the potentiometer itself. This point was further demonstrated by the fact that ripple on the output terminals (with  $C_2$  out of circuit) increased as  $R_2$  slider approached the centre of the track. With  $C_2$  in circuit, ripple was negligible at all output voltages.

#### Alternative Zener Circuit

As has been described, part of the current available from the mains transformer secondary has to be diverted to the zener diode and potentiometer section. If the added complication is considered worthwhile the zener diode and potentiometer can be run from an alternative

supply, whereupon the total h.t. secondary current becomes available for the output circuit.

A suggested method of supplying the zener diode section is shown in Fig. 4. This assumes that the mains transformer has two 6.3 volt heater windings which can be connected in series. Four silicon diodes (which could be Lucas type DDOOO) are connected in a bridge circuit, the rectified voltage being applied, via resistor  $R_7$  to the zener diode. Resistor  $R_3$  remains in circuit as before. Since there is now no limitation on the current available for the potentiometer this current can be increased, with a consequent improvement in regulation. In Fig. 4 the potentiometer value is reduced to 500Ω, and it is re-designated  $R_8$  in consequence. The value of resistor  $R_7$  is adjusted such that about 10mA flows through the zener diode. When the zener diode is stabilising, the current through  $R_8$  will be of the order of 24mA.

The writer has not tried the modification of Fig. 4 in practice, and presents it as an experimental project. Alternative methods of supplying the zener diode and potentiometer may also occur to the reader.

A final point is that, if the power supply unit is built up as a piece of bench equipment, it would be desirable to provide it with a pilot lamp. Such a lamp can be conveniently run from any heater winding which may be fitted to the mains transformer.

## ECONOMY PARKING LIGHT CONTROLLER

By F. C. Judd, A.Inst.E.

WHEN LITTLE BUFF COLOURED TICKETS APPEAR under your windscreen wipers the time has arrived to install a parking light and,

moreover, to make sure it is *on* at the right time and *off* when not required. So far as the latter is concerned the answer is, of course, simple: just plug in the parking light when it gets dark and unplug it again at daybreak.

But can you always remember to dash out to the car at lighting up time? If you forget, the buff coloured ticket will appear in stronger terms. And, also, who wants to crawl out of bed in the cold grey dawn to switch a parking light off? On the other hand, leaving the light permanently plugged in for long periods will slowly but surely discharge the car battery.

The circuit shown in Fig. 1 provides the solution to all these problems, and, whilst a parking light controlled by a photocell is nothing new, the writer feels justified in making at least one small claim for this one, i.e. economy. It is also very reliable, having been in continuous use now for several weeks, faithfully switching the parking light on at dusk and off at dawn.

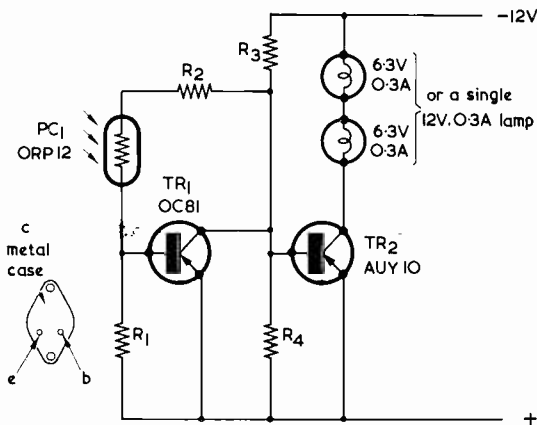

Fig. 1. The circuit of the parking light controller

### Components List

#### Resistors

(All resistors 10% 1/4 watt)

- R<sub>1</sub> 6.8kΩ
- R<sub>2</sub> 68Ω
- R<sub>3</sub> 2.2kΩ
- R<sub>4</sub> 4.7kΩ

#### Transistors

- TR<sub>1</sub> OC81
- TR<sub>2</sub> AUY10 (see text)

#### Photocell

- PC<sub>1</sub> ORP12

#### Lamps

- 2 lamps, 6.3 volt 0.3 amp (or single 12 volt 0.3 amp lamp)

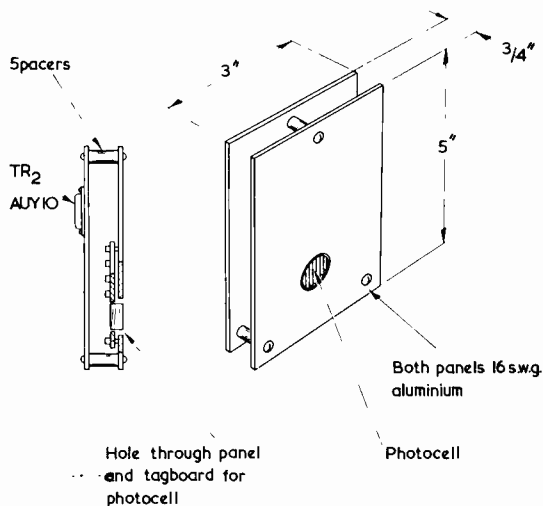

Fig. 2. How the unit is assembled. TR<sub>2</sub> is bolted directly to the rear aluminium panel, which acts as a heat sink and provides the collector connection

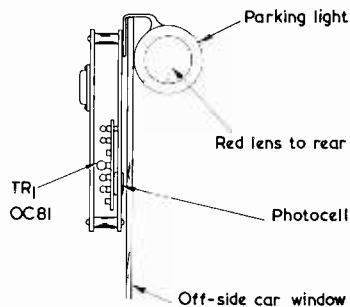

Fig. 3. Fitting the unit to the off-side window of the car

### No Relays

The circuit is simplicity itself and, unlike most of these gadgets, does not employ a relay which necessitates a fairly high working current, even during the "off" period. The photocell controls the current taken by TR<sub>1</sub> (OC81) which, in turn controls the current taken by TR<sub>2</sub> (AUY10). When TR<sub>2</sub> is conducting the current taken by the collector is quite sufficient for adequate brilliance of the lamps and at maximum is 0.2 amp. During daylight TR<sub>1</sub> takes about 3mA and TR<sub>2</sub> takes no current at all—lamps extinguished. Note that the circuit is designed for 12 volt battery operation only.

The photocell is the type used for controlling the contrast of TV receivers and is not affected by ambient street lighting at night. The writer's car on which the device has been in use for some time is parked directly under a large sodium street light. Some may consider the AUY10 transistor as being a little on the expensive side, but better this than a fine. It is possible, of course, that a cheaper power transistor might work just as well.

### Construction

The construction is quite simple, and is shown in Fig. 2. The heat sink for the AUY10 becomes part of the chassis. Other components and the photocell must be insulated from both panels of the chassis. Observe carefully the polarity of connections to the car battery and *make sure the chassis does not come into contact with metal parts of the car.*

When the device is mounted on the side window, as shown in Fig. 3, the lamp is outside and the controller is inside, with the result that the window can be closed right up. The parking light can be any suitable type obtainable from garages but, of course, modified to take the two 6.3V 0.3A lamps.

### Editor's Note

A lower-cost transistor for the TR<sub>2</sub> position would be the OC29, which has the same terminal connections as the AUY10. Some transistors may exhibit low gain and it may be necessary to slightly reduce the value of R<sub>3</sub> to obtain sufficient current through the lamps.

---

---

# SINGLE TRANSISTOR AUDIO OSCILLATOR

By J. S. BROWN

---

---

NEEDING A SINGLE-TRANSISTOR OSCILLATOR RE-  
cently, the writer remembered the Colpitts  
oscillator described by G. A. French in  
*The Radio Constructor* dated January, 1964.\*

In the form given, and as G. A. French pointed  
out, this circuit suffers from several disadvantages  
in that it requires two batteries, and that taking  
the output from the relatively high impedance  
collector limits its use to feeding high impedances.  
When the writer wired up the circuit and examined  
the collector waveform he found, also, that this  
was very non-sinusoidal.

The oscillator was, in consequence, subsequently  
modified to that shown in Fig. 1. The new circuit  
overcame the disadvantages and was found to be  
very satisfactory indeed.

---

\* "The 'Chicane' A.F. Oscillator" (Suggested Circuit No. 158).  
This oscillator employed a Colpitts circuit in which the inductance  
could be provided by a pair of headphones which also reproduced the  
a.f. tone.

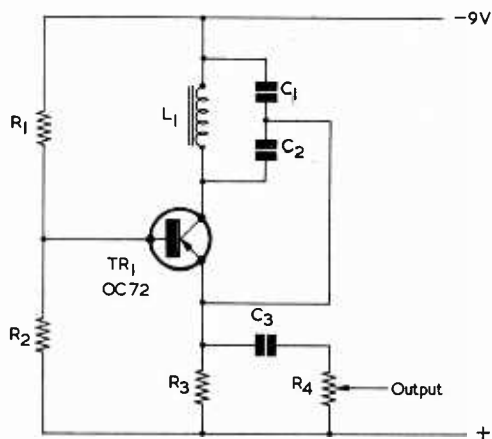

Fig. 1. The circuit of the single transistor oscillator

## Emitter Output

It will be noted that the output is taken from  
the emitter. This method of operation has two  
advantages. Firstly, the waveform at this point  
is the purest sinusoid the writer has ever seen from  
a one-transistor oscillator and, secondly, the  
oscillator is capable of feeding into a low impedance  
(although the output naturally falls).

A possible disadvantage is that the amplitude  
at the emitter is, of course, less than that available  
at the collector. The actual figures obtained were:  
0.1 volt peak-to-peak into a 300 $\Omega$  load, 1 volt  
peak-to-peak into a 5.6k $\Omega$  load and 2 volts peak-to-  
peak into a load of 33k $\Omega$  and above.

The big advantage of the circuit, as was pointed  
out by G. A. French, is that the inductance may  
vary between wide limits (the headphones themselves  
can be used in the case of Morse code practice).

## Components List

### Resistors

(All fixed values  $\frac{1}{4}$  watt 10%)

- R<sub>1</sub> 56k $\Omega$
- R<sub>2</sub> 10k $\Omega$
- R<sub>3</sub> 4.7k $\Omega$
- R<sub>4</sub> 50k $\Omega$  potentiometer, log track. (May be  
smaller with low impedance loads.)

### Capacitors

- C<sub>1,2</sub> See text
- C<sub>3</sub> 0.05 $\mu$ F

### Inductor

- L<sub>1</sub> See text

### Transistor

- TR<sub>1</sub> OC72 (or OC70, OC71, OC75, OC83, etc.)

### Battery

- 9-volt battery

The inductor used by the writer was half the secondary of an interstage transistor transformer taken from a commercially manufactured receiver. The winding used "bridged" at 4.4H on an inductance bridge. The frequency may be adjusted by altering  $C_1$  and  $C_2$ , and it should be noted that  $C_2$  should be one tenth to one half of  $C_1$ .

The frequency of the writer's circuit was approximately 500 c/s with  $C_1 = 0.1\mu\text{F}$  and  $C_2 = 0.05\mu\text{F}$ , this being more pleasant to listen to than, say, 1,000 c/s. If, however, the oscillator should be used to feed a bridge, then 1,000 c/s is to be preferred because the ear is more sensitive to 1,000 c/s than to 500 c/s.

The circuit is very tolerant of transistor types. For example, an OC83 was fitted in place of the OC72, and no significant difference in performance was observed. Using a 4.5 volt battery, the output was a little more than a half of that obtained with the 9 volt battery. Current consumption at 9 volts was 0.5mA.

#### Editor's Note

After carrying out later checks, the author states that total harmonic distortion measured 4% and that this would not normally be detectable on an oscilloscope. He also obtained the waveforms shown in Fig. 2. It will be noted that, due to energy return in the inductor, the collector swings through 12 volts peak-to-peak. The distortion figure just quoted should be considered in relation with the relatively high output and, in particular, the simplicity and flexibility of the circuit.

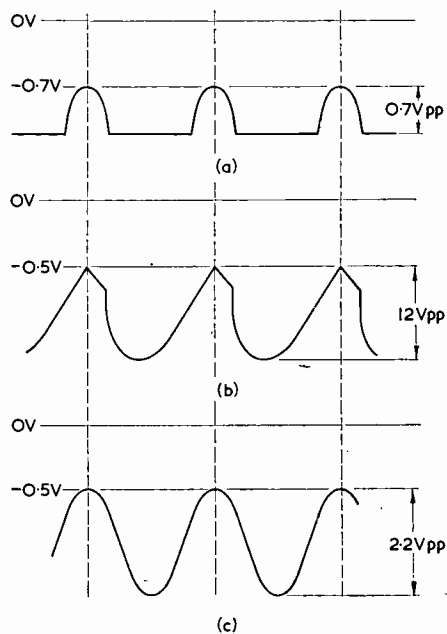

Fig. 2. Waveforms given by the prototype at (a) the base, (b) the collector and (c) the emitter. The zero voltage line corresponds to the positive supply line in Fig. 1

## HENRY'S NEW CATALOGUE

Currently available is the 1966 Catalogue of components and equipment stocked by Henry's Radio Ltd., 303 Edgware Road, London, W.2. This new catalogue is much larger than previous editions, and it contains 152 pages which list over 5,000 items.

The items listed include valves, semiconductors, crystals, test equipment, high fidelity equipment and accessories, complete kits and ready-built units. Also in the catalogue are coils, transformers, relays, photocells, and all the other components employed by home-constructors and experimenters. To take an example of the range provided, there are over 500 semiconductors; and a particularly useful feature is the provision of basic information on each device, this including such details as lead-out connections, type (i.e. p.n.p or n.p.n., and germanium or silicon), power dissipation and maximum operating frequency.

Forty-one pages are devoted to high fidelity equipment from over 40 manufacturers, including Acoustical, Leak, Decca, S.M.E., and Jordan Watts. Another section of the catalogue deals with complete broadcast receivers, communications receivers, p.a. equipment and tape recorders. The catalogue is profusely illustrated with line drawings and photographs.

The catalogue may be obtained from Henry's Radio, Ltd., for 5s. (plus 1/- postage and packing). It contains three 2s. discount vouchers, each of which can be presented with every pound's worth of equipment ordered.

#### Pocket Valve Voltmeter

The "Pocket Valve Voltmeter" described in our December 1965 issue has proved to be very popular amongst readers. Several constructors have stated, however, that they have been unable to obtain sufficient anode and screen-grid current in the DL96, and we have found that this has been due to the use of an unbranded valve. No troubles have been experienced when a Mullard DL96 is employed. As a guide, valve current should not be less than  $30\mu\text{A}$  with the 8.2 volt supply.

#### Communication by Modulated Arc Beam

The caption shown under the illustration on page 434 and that at the top of page 436 should be interchanged.



## Portable Microwave Terminal can carry Radio, Radar and TV

A portable microwave communication terminal hardly bulkier than an attaché case has been demonstrated by the Transmission Systems Group of Standard Telephones and Cables Limited. Known as the "Pico" terminal it is capable of carrying speech, radar, or television signals.

The complete Pico terminal is housed in a one cubic foot weatherproof package with self-contained aerial and weighs a mere 17lb—figures achieved by extensive use of microelectronics.

Key features of the new terminal are its flexibility and ease of setting up and operation. Using pulse code modulation (p.c.m.) it can carry up to 96 telephone channels or with frequency division multiplex (f.d.m.) up to 600 channels. Alternatively, video signals (television or radar), or wideband data signals may be carried. It can be used with a separate dish aerial and with additional modules can provide tropospheric scatter transmission.

Pico has important military applications due to its self-contained portability, in particular for the remoting of various types of radar signal. As a multi-channel communication link it has several potential roles.

Civil television applications are likely to be as an outside broadcast link, and as a TV relay, e.g. for industrial or security purposes. Pico's size, weight and reliability also offer distinct advantages in disaster and emergency communications, and in conditions where temporary communications are called for, for example in power or pipeline construction.

Pico has been designed by ITT Federal Laboratories in the U.S.A. (an STC associated company) and will be manufactured by Transmission Systems Group at STC's Basildon plant.

STC can offer a wide range of equipment for use in conjunction with Pico, including transistorised portable 4-channel frequency division multiplex, 24 channel p.c.m. multiplex, and telegraph, telemetering and data communications equipment.

Pico uses a linear modulator-demodulator system to accommodate simultaneous multi-channel or broadband traffic in the range 4.4 to 5.0 Gc/s or 7.125 and 8.5 Gc/s. The power output is 0.2W using varactor diodes; a 1.0W version is available, weight 27lb. The receiver noise figure is 10dB. An i.f. of 70 Mc/s is used and the i.f. bandwidth is 35 Mc/s.

Pico utilises Federal Labs' "thick film" microcircuitry—a development of thin film technology giving more robust construction and easier servicing.

## 100 "Old Timers" for R.F.C. Reunion

One hundred men, now in their sixties and seventies, who as World War I radio operators worked on the French battlefields with the Royal Flying Corps, will gather for their 28th annual reunion, at the Victory Ex-Services Club in London, as this issue comes off the presses.

They are members of the Royal Flying Corps Wireless Operators Old Comrades Association formed in 1930 with a membership of 12. It has now grown to an organisation with 250 members. Almost every year, except during the war, reunions have been held in London, and despite their age, back come the "old-timers" year after year for their evening of comradeship and memories.

Early in World War I the call went out for volunteers to join up as wireless operators, although airborne wireless telegraphy was then still in its infancy. Only after the second Battle of the Somme did air-to-ground wireless communication begin to come into its own. Many were trained first at the Regent Street London Polytechnic, and afterwards at the R.F.C. Wireless School at Farnborough. They went to France, where R.F.C. pilots, after reconnoitring enemy targets to assess the extent of damage done by Allied artillery fire, would fly back and report by Morse from their aircraft what they had seen. The operators, unable to answer in Morse as there was still no two-way communication, sent the pilots' replies in code by laying out strips of white cloth and relayed the pilots' information to headquarters.

Organiser of the reunion is Mr. E. J. F. C. Hogg, M.B.E. (67), of London. He still owns the 1916 newspaper advertisement for wireless operators aged between 18 and 21 which led him to join the R.F.C.—at the age of 17.

## Amateur Maritime Operation

The Post Office, after consultation with the Radio Society of Great Britain, has recently completed a review of the conditions under which amateur maritime operation has been authorised since 1952.

A new form of Amateur (Mari-

# COMMENT

## First Educational Television O.B. Unit

time) Licence has now been introduced for an experimental period of two years. It authorises transmissions on the frequencies in the 7, 14, 21 and 28 Mc/s amateur bands which an applicant specifies in his application for a licence, and on any frequency in the 144-146 and 21,000-22,000 Mc/s amateur bands. Transmissions on authorised frequencies between 7 and 29.7 Mc/s must be crystal controlled. Use of frequencies in the 1.8 and 3 Mc/s amateur bands cannot be authorised.

Further information and application forms for an Amateur (Maritime) Licence may be obtained from the Radio Services Department, Radio Branch, General Post Office, Headquarters Building, St. Martin's-le-Grand, London, E.C.1.

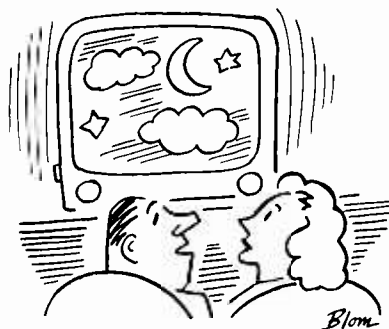

"I told you the aerial was too high."

### Quote

There is a story that the comedians Frank Muir and Denis Norden once presented a model of the battleship *Potemkin* to the Director-General of the Independent Television Authority to warn him of what happened when the ratings got the upper hand. The reference was to audience ratings, which measure the popularity of programmes.

It is sometimes urged that another replica of the warship should be presented to B.B.C. television on the ground that it, too, has elevated audience-chasing into a religion and lost its dignity and integrity in the process. The truth is more complex.

From an article, one of a series of five, which appeared in *The Times* under the title *Television: The Rivals' Progress*.

The University of Glasgow has taken delivery of what is claimed to be the first television outside broadcast unit to be designed for an educational establishment in the United Kingdom. The four-camera unit, supplied by the Marconi Company, contains all the facilities normally found in an educational studio control room and has cost the University approximately £16,000.

The unit will be used to record lectures on video tape for subsequent use by the University of Glasgow and associated educational establishments. It will also be used to link lecture theatres within the University so that more students can "attend".

Three lightweight vidicon television studio cameras fitted with electronic viewfinders are provided. Two have four-lens turrets and the other is fitted with a zoom lens. The cameras are simple to use and can be operated at distances of up to 500ft from the vehicle using the cables provided. The camera complement is completed with a caption camera. This is normally housed in the vehicle, but can be used externally with a boom for such purposes as recording surgical operations.

Full vision mixing facilities are provided for the four cameras and sound mixing for up to eight microphones and four high-level sources. In addition to the normal communication facilities between the producer and the camera and sound crews, facilities are provided for students in the linked lecture theatres to communicate with the lecturer.

A keynote of the new O.B. unit is the simplicity of operation. None of the controls, which are situated on a control desk beneath five 8½in monitors, have to be operated by engineers during transmission.

The caption camera is placed to one side of the control panel. Its copy table can be lit from above or below and will, therefore, accept ordinary artwork or transparent material such as that used to illustrate lectures. Size of material is not important as the caption camera is fitted with a zoom lens.

Distribution amplifiers contained in the vehicle each provide five output signals. These can be used to feed lecture theatres or video tape recorders. A table is provided in the vehicle's control room for a helical scan video recorder.

The O.B. unit requires no special power supplies and will operate from any 13 amp mains supply.

*The Pico terminal is simple to set up and to operate. We show in the accompanying illustration the link being used for telephone communication.*



# Vacuum or Solid-State?

R. S. Thornton

*Our contributor examines the current situation in the tug-of-war between the valve and the semiconductor*

**T**HERE ARE FEW ENGINEERS TODAY WHO WOULD choose to use valves in any application where transistors could be employed. This bald summary of the present position underlines the remarkable progress in the development of transistors and other semiconductor devices in the last five years. It used to be stated with considerable confidence by valve engineers that vacuum devices would always be predominant in the "four highs": high temperature, high frequency, high power and high input impedance. These cosy beliefs have all been considerably eroded; indeed the last one has been thoroughly shattered by the arrival of the metal-oxide-semiconductor field effect transistor, mercifully abbreviated to MOSFET.

The valve industry has, however, struck back against the encroachment of semiconductor devices. The rapid development of ceramic-metal sandwich construction has enabled triode and tetrode valves to replace some microwave devices just as transistors are replacing the more conventional valve at lower frequencies. The adoption of the "frame-grid" technique, well known in small transmitting valves, to smaller "receiver" types has prolonged the life span of a class of valve rapidly becoming obsolete.

Let us examine the present position as it exists in each application for active devices.

## Domestic Radio And Hi-Fi

In domestic radio equipment, the valve is fighting a losing battle. Transistors dominate entirely the "personal portable" market, are well established in the larger "table radio", and have a significant foothold in the latest radiograms. The pocket radio owes its existence, of course, to the transistor,

the once familiar valve operated portable having been quickly made obsolete by reason of its weight, size and appetite for batteries. The existence of f.m. sound broadcasting prevented the equally rapid replacement of valves in table radios until the price level and performance of high-frequency transistors became commercially and technically attractive. The radiogram market has been the last of the domestic radio group to succumb to the transistor. Though the performance of power transistors has for some time been quite adequate for use in radiograms, the price factor has been marginally prohibitive, especially at the pre-amplifier end where designers were faced with the dilemma of high-impedance, inexpensive crystal pick-ups with at least two transistors to match up to the high impedance, or expensive low-impedance magnetic pick-ups, matching well but requiring more gain. The two answers in sight at the moment are the Mosfet with its high input impedance and, on the other hand, cheaper, mass-produced magnetic pick-ups. The "ultimate" answer may be the amplifier produced recently by an American firm. This uses one single active device, a Mosfet, in an amplifier producing an output of one watt from the input of a crystal pick-up.

The Hi-Fi market is now being very rapidly penetrated by transistors. Whether or not there is a distinctive "transistor sound" is a matter for subjective judgement; objectively, transistors have the usual advantages of small weight, size and heat dissipation, but the most telling point is the use of output stages requiring no output transformers. In a market where price is of secondary importance, the lower performance/price ratio for power transistors as compared to valves might be thought irrelevant but, in fact, the difficulty of obtaining the very high standards set by the leading makers of valve amplifiers with currently obtainable power transistors, at an economic price, has delayed the extensive use of transistors by several years. The dyke has now been breached, however, and the flood cannot long be delayed.

## Television

Television obstinately remains dominated by the valve, and the principal reason for this is the low price of the line output valve. Although much has been and is being done to reduce the dissipation in this stage, the scanning and e.h.t. requirements of present day wide angle tubes set a definite limit on the advantages which higher efficiency can bring. Suitable transistors and circuits capable of solving the triple problem of high dissipation, high voltage and rapid switching exist, but not at competitive prices. In addition to this, the use of high-gain frame grid valves in current TV sets has reduced the valve complement to a new minimum, creating a very formidable economic barrier for the transistor to conquer.

There are, however, two clouds on this happy valve horizon. One is the mains/battery portable TV set, which now seems to be settling into some-



thing more than a passing fashion. Not only are these small-screen sets taking a large part of the "second-set" market, they enable manufacturers to gain experience of the techniques which will eventually spread to larger sets. The other shock to valve supremacy is the increasing use of transistors in u.h.f. tuners. Very few engineers could have predicted five years ago that transistors would start to replace valves in u.h.f. tuners before they had gained a substantial foothold in other parts of the TV set. The excellent low-noise performance of recent u.h.f. transistors has also led to their increasing use in mast-head pre-amplifiers; the claim has been made, in fact, that it is now more rewarding to use a mast-head pre-amplifier than to increase the height or complexity of an aerial array.

### The Instrument Industry

Passing rapidly over the computer scene, where even transistors seem to be very much out of date, we see the valve in decline in the instrument industry. In the U.S.A., valves in instruments—apart from such things as gas-filled valves and display devices in counters—seem to be confined mainly to oscilloscopes, and there are signs that this application may soon also vanish as silicon transistors with very high collector voltage ratings become available. Another factor aiding the use of transistors in oscilloscopes is the development of cathode ray tubes using metal meshes to separate the deflection fields from the final accelerating fields. This technique provides very high deflection sensitivity along with the brilliance of trace demanded of modern tubes. Even the electrometer valve seems threatened now that the very high impedance Mosfet is available. One of the greatest advantages of transistorised instruments is, of course, battery operation. Anyone who has set up two signal generators, a power pack, and an oscilloscope to test a mixer stage, and has then tripped over the resulting tangle of mains cables will certainly welcome the trend to battery operation.

### Industrial Applications

In industrial uses, the valve reigns supreme, although silicon rectifiers have been slowly and quietly replacing valve units for some time now. There is no transistor development on the horizon which seems even remotely likely to replace the valve in r.f. heating equipment. The thyristor, or silicon controlled rectifier, has a long way to go before it can economically replace the larger thyatron and the ignitron. The main industrial objective at the moment for transistors must be instrumentation and control and, indeed, steady progress is being made. There are some signs that transistors will replace valves in the smaller type of ultrasonic cleaner; one interesting possibility is the use of the cleaning medium as a heat sink for the power transistor(s), thus making separate heating unnecessary and enabling higher output powers to be achieved.

### Communications Equipment

As far as communication applications are concerned, the valve and transistor fight on level terms. There is, of course, no dispute at the extreme ends of the power range.

At output powers of one kilowatt and over, valves and other thermionic devices are used almost exclusively. Two trends are noticeable. One is towards the use of valves of ceramic construction up to frequencies which, until comparatively recently, were the province of microwave devices of rather lower power output. The other trend is towards very high power microwave valves, in the region of several hundreds of kilowatts of c.w. output. High power magnetrons have been with us for some time, of course, but these I speak of are generally of the klystron family. This is rather ironical, as the small klystron, so long used as a local oscillator in microwave receivers, is in danger of being replaced by various semiconductor devices such as tunnel diodes. Much work has been done on "crossed-field" devices, such as the "Amplitron" for very high output powers at microwave frequencies.

At the other end of the scale of power, the transistor is undisputed champion of the field of portable, as distinct from mobile communication. It is indicative of transistor progress that the dividing line can no longer be drawn on a basis of frequency, as was once the case when only the lower frequency portable equipment could be transistor operated. Some of the equipment in this category is of considerable interest, ranging as it does from the multi-channel closed-loop paging systems through the American "Citizen's Band" transceivers to the most highly sophisticated "walkie-talkie" and its television equivalent, the "creepie-peepie".

In mobile communications, the battle is still raging. Output powers are higher here, and transistors are economically at a disadvantage. The advent of output valves with exceptionally short warm-up times (100 milliseconds is often quoted) has done much to defer any large scale swing over to transistors. Some very recently announced valves feature remarkably high transconductance (over 100mA/V) and, due to the use of frame-grid techniques, can pass high currents at low anode voltages.

### Heaters And High Voltages

The eternal disadvantages of the valve remain the necessity for heaters and high voltages. The cold cathode valve using tunnel effect in a semiconductor cathode remains a dream as far as the designer is concerned. High voltage is less of a disadvantage. Modern valves, as stated above, work at low anode voltages. The higher power transistors require fairly high line voltages (50V or more) and if a valve output stage can be operated at 90V there is much to gain financially from using the valve, particularly if the high voltage has to be obtained from a 12V battery via a transistor or (In the higher power range) a thyristor anyway.

At lower powers where the battery supply can be used directly, the transistor comes into its own again.

### The Future

What of the future? Inevitably, I feel, the valve will have less of the power spectrum. Already, varactor diodes are being used in highly efficient

frequency multipliers to give outputs of several hundred watts at over 1,000 Mc/s. Once the familiar see-saw of price and demand has tipped over, the valve will probably be a rarity at output powers of less than a kilowatt. As the power and frequency spectra stretch upwards indefinitely, but downwards finitely, valves have by no means the worse part of the bargain!

# Home or Office Intercom System

By P. J. Best

*Telephone handsets which require no transformers provide a very simple intercom system for use in the home or office*

THE WRITER HAS READ MANY articles on intercom telephones and has experimented with a number of different circuits. He finally decided to make up a very simple intercom system between two points using two interconnecting wires only, this providing both call-up and speech facilities. The simple circuit employed appears in the accompanying diagram.

### Circuit Operation

The components at each station consist of a bell or buzzer, a battery, a single pole changeover switch, a push button, and a telephone handset of a type which may be connected directly to the circuit via two wires and an energising battery only.

When not in use, the switch at each station is left in position 1. To call station B, the operator at station A throws his switch to position 2, this bringing his telephone handset into circuit. A circuit is now completed from the positive terminal of the battery at station A, through the bell at station B, through the handset at station A, and back to the negative terminal of the battery at

station A. The current which flows is not, however, sufficient to cause the bell at station B to sound. The operator at station A next presses his push button. This short-circuits the handset and applies the battery at station A direct to the interconnecting lines. The bell at station B now sounds.

On hearing the bell, the operator at station B throws his switch to

position 2, bringing his handset into circuit, whereupon a telephone conversation may take place. The circuit is this time given from the positive terminal of the battery at station A, through the handset at station B, through the battery at station B, through the handset at station A, and back to the negative terminal of the battery at station A.

When the conversation is complete, both operators return their switches to position 1.

### Polarity

For correct operation the stations should be connected together, positive to negative, in the manner shown in the diagram, as this enables the two batteries to be series-aiding when the handsets are switched in. The intercom system will not function on speech if the polarity indicated is not observed.

The handsets are designed to operate from a single energising battery (one battery in series with a pair of handsets) having a voltage between 1.5 and 12, although the suppliers state that battery volts may be increased above 12 for communication over long distances. In the present circuit there are two energising batteries in series and these may, for short distances, be 4.5 or 6 volts each. The writer uses his system over a relatively long distance and employs a 9 volt

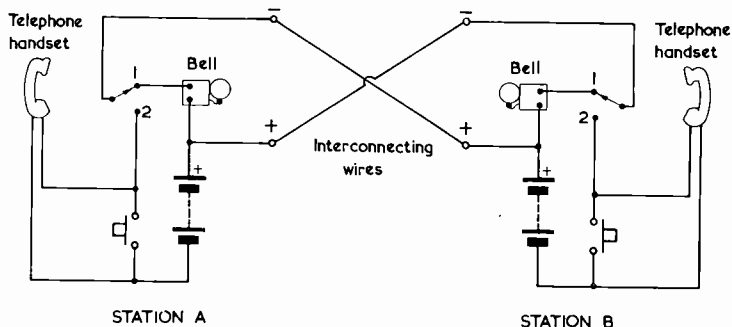

*The circuit of the simple telephone intercom. It is important to ensure that the interconnecting wires between the two stations are connected as shown here. The batteries should be 4.5 or 6 volt types if communication is not required over long distances*

battery at each station, this being given by two 4.5 volt bell batteries in series. The constructor should check results with lower voltage batteries before using a voltage higher than 6 at each station.

The system may employ a single interconnecting wire if an "earth" conductor, such as a water pipe, is available between the two stations.

This intercom has many applications and can, for instance, be fitted between rooms in a house, between house and workshop or garage, or between offices. At the time of writing, the author's system has been

in use for over a year and has given no trouble.

So far as components are concerned, the only items which need comment are the handsets. These are intended for two-wire working without transformers and are available from Duke & Co. Ltd., 621 Romford Road, Manor Park, London, E.12.

#### Editor's Note

It should be mentioned that if, when both switches are in position 2, both push buttons are pressed at the same time, the batteries are short-circuited via the interconnecting

wires (whose resistance will limit the short-circuit current which flows). The chance of both buttons being pressed at the same time is slight, and the author states that no problem has occurred on this score with his own system. The risk could, in any case, be avoided by refraining from pushing the button if listening to the handset indicates that the other station is on position 2.

The changeover switch at each station could, if desired, be incorporated into a hook for the handset, this switching to position 1 when the handset is hung up.

## Recent Publications . . .

**CIRCUITS USING DIRECT CURRENT RELAYS.** By A. H. Bruinsma. 86 pages, 8½ x 5½in. A Philips Paperback distributed by Iliffe Books Ltd. Price 13s. 6d.

To those who are interested in radio control and robot circuits, A. H. Bruinsma needs no introduction. His present book commences with general data on d.c. relays and relay operation, then carries on to delayed operation, short-term operation and operation by light or tape signals. In the last case a tape may have a commentary recorded on one track and pulses on a second, whereupon the pulses can control the operation of, say, a projector.

Later chapters deal with commanded sequence circuits (including bistable and counting circuits), automatic sequence circuits with commanded start, and oscillating circuits. The final chapter is devoted to miscellaneous circuits, including one for adding and subtracting.

There is a special fascination about the subject of this book, and the reader will find that it contains many ingenious circuits. The translation from the Dutch is somewhat literal—in Fig. 1 a residual stud is described as a "copper anti-sticking ridge"—but this will not deter the experimentally-minded reader who is on the search for new ideas and applications.

**TAPE RECORDER SERVICING MANUAL.** By H. W. Hellyer. 341 pages, 7½ x 10in. Published by George Newnes Ltd. Price 63s.

Following the pattern set by the Newnes *Radio and Television Servicing* volumes, this book provides concise information on tape recorder products under no less than 62 trade names. Service details on tape decks on their own is given for B.S.R., Collaro, Garrard, Motek, Korting, E.M.I., Thorn and Truvox, and also dealt with is the Gramdeck. The remainder of the information is for complete tape recorders.

A short introductory section on tape recorder servicing precedes the material on manufacturers' products, the latter taking up almost the whole of the book. The servicing details include all applicable circuit diagrams, and are compiled from the manufacturers' official data, from trade sources and from bench notes and observations made by the author as the result of practical servicing experience.

**TRANSISTORS WORK LIKE THIS.** By Egon Larsen. 62 pages, 6½ x 10in. Published by Phoenix House Ltd. Price 11s. 6d.

*Transistors Work Like This* is intended for the newcomer, and will be of particular value to any youngster who shows a budding interest in electronics. But this does not mean that the book is in the "popular science" category—it is factual and the technical information given, which extends to notes on microcircuits, is sound. An interesting feature is the historical approach to some of the devices referred to. The author tags dates and names on to many of the developments described, and also gives a large number of figures to qualify currents, voltages, powers, and the like.

This book could be just what your young nephew needs for his birthday; and it includes, indeed, a short chapter dealing with careers in transistor electronics.

**RADIO SERVICING. Vol. 2—Intermediate Radio Theory.** By G. N. Patchett, B.Sc.(Eng.), Ph.D., M.I.E.E., M.I.E.R.E., M.I.E.E.E. 160 pages, 5½ x 8½in. Published by Norman Price (Publishers) Ltd. Price 10s. 6d.

This is a new and enlarged edition of the book, which first appeared in 1956, and it is intended to cover the syllabus of the intermediate examination in Radio and Television Servicing held by the City and Guilds and the Radio Trades Examination Board.

Valve and transistor circuits are dealt with side by side, and the subjects covered range from transmission and reception through valve and semiconductor operation and circuits, amplifiers, power supplies and receivers, to the elements of television. The use of a type which is slightly smaller than usual enables a larger amount of text to appear than would normally be the case, and makes the book a very economical choice.

The author is Head of the Department of Electrical Engineering at Bradford Institute of Technology, and the book can be thoroughly recommended to students working for the examination just mentioned or for anyone who requires a good reliable textbook up to this level.

# The

# "U" N I T Y

By  
D. B. PITT

## Light Programme Receiver

*If you live in the strong signal area for Droitwich and have a good aerial and earth, this low-cost single transistor receiver can bring you the Light Programme at loudspeaker strength*

**T**HIS ARTICLE DESCRIBES A CHEAP AND MODERATELY simple receiver designed to give loudspeaker reproduction of the Light Programme on 1,500 metres (200 kc/s). It uses one transistor only and this is of the inexpensive a.f. type.

The receiver can be reasonably expected to give satisfactory results in any area where crystal-set reception of the Light Programme on the long waveband is possible, using a good aerial and earth. The writer, who lives 60 miles from the Light Programme transmitter at Droitwich, has obtained very acceptable results using a simple dipole aerial (and its down lead) intended for v.h.f. reception, attached to a chimney 20ft above ground level.

Such a statement about performance gives little information where other wavebands are concerned. But reception on 200 kc/s is largely independent of intervening obstacles and terrain, and alters comparatively little between daylight and darkness, so here it is reasonably meaningful.

### Using One Transistor

Loudspeaker reception can be obtained from one transistor because the received frequency happens to be low, and because a reflex circuit is employed. A reflex receiver is one which amplifies at two (at least) different frequencies, generally at r.f. and a.f. This receiver amplifies not only at two different frequencies but in two different modes, the r.f. amplification being in common-base mode and the a.f. amplification in common-emitter mode.

This arrangement obtains the best of both worlds, combining the extended frequency range of common-base with the high voltage gain of common-emitter. A cheap a.f. type transistor can thus be used to achieve both r.f. and a.f. gain, provided the r.f. does not exceed about 500 kc/s or so.

### The Circuit

The theoretical circuit appears in Fig. 1.  $R_1$  and  $R_2$  provide the base bias by potential divider action, whilst  $R_3$  ensures thermal stability, this resistor being bypassed by a large value electrolytic capacitor,  $C_6$ , to avoid loss of a.f. gain.

The signal is applied to the primary,  $L_1$ , of the step-down r.f. input transformer and the induced voltage in the secondary,  $L_2$ , is fed to  $TR_1$  emitter. The base of  $TR_1$  is earthed for r.f. by  $C_2$  which, however, offers a fairly high impedance to a.f. signals. Common-base amplification therefore takes place and a magnified image of a fairly broad band of r.f. signals passes through  $C_1$  to the tuned circuit formed by  $L_3$  and  $C_3$ .

This tuned circuit, preset to 200 kc/s, passes this frequency to  $D_1$  where detection occurs. The a.f. signal appears across  $R_4$  and is fed via  $C_5$  to  $TR_1$  base.

Since the base is *not* earthed for a.f. purposes, while the emitter *is*, common emitter amplification of the audio signal takes place and the amplified a.f. signal at  $TR_1$  collector is passed to the transformer,  $T_1$ , whose output matches the impedance of the speaker.

Readers may now have noticed another unusual feature of this circuit. Not only does it amplify in two different modes, but r.f. amplification takes place before tuning instead of after tuning.

This principle is only very rarely encountered in t.r.f. receivers, though it is common enough in v.h.f. designs. It is used because the receiver is preset to one station only, and this fact immediately removes a number of design problems whilst retaining all the advantages of the reflex principle.\*

### A Simplified Version

A simplified form of the circuit, suitable for areas fairly close to Droitwich, say within 30 miles, can be obtained by removing  $R_2$ ,  $R_3$  and  $C_6$ , connecting the lower end of  $L_2$  direct to the positive supply line, and by changing the value of  $R_1$  from 33k $\Omega$  to 100k $\Omega$ . Supply voltage for this simplified circuit should not exceed 4.5 volts. With this arrangement there is, of course, no thermal stabilisation.

\* The writer informs us that, due to the very low r.f. input impedance of the transistor, it is necessary to give the input transformer,  $L_1$ ,  $L_2$ , a ratio of about 20:1 to 30:1. Whilst it is feasible to attempt tuning  $L_1$  to 200 kc/s in order to increase gain, the improvement in practice is disappointingly small. In the writer's opinion, it is hardly worth the cost of a fixed capacitor and certainly not a variable capacitor.  
—EDITOR.

## Components List

### Resistors

(All resistors 10%  $\frac{1}{4}$  watt)

- R<sub>1</sub> 33k $\Omega$
- R<sub>2</sub> 10k $\Omega$
- R<sub>3</sub> 220 $\Omega$
- R<sub>4</sub> 33k $\Omega$

### Capacitors

- C<sub>1,2</sub> 0.01 $\mu$ F
- C<sub>3</sub> 0.002 $\mu$ F
- C<sub>4</sub> 0.01 $\mu$ F
- C<sub>5</sub> 8 $\mu$ F electrolytic 6V wkg.
- C<sub>6</sub> 50 $\mu$ F electrolytic 3V wkg.

### Inductors

- L<sub>1,2</sub> R.F. input transformer. (May consist of modified Repanco choke type CH1—see text)
- L<sub>3</sub> Tuning coil (see text)
- T<sub>1</sub> Output transformer. Type LT700 (Rex)

### Semiconductors

- TR<sub>1</sub> XB103 (see text)
- D<sub>1</sub> OA70 or equivalent

### Speaker

Large diameter, high-gauss, 3 to 5 $\Omega$  impedance

### Switch

S<sub>1</sub> s.p.s.t.

### Battery

9-volt battery

The output is similar, but the gain is somewhat less. The simplified circuit is, however, three components cheaper, and as one of these components is an electrolytic capacitor the modification may be justified.

### Constructional Points

The components may be laid out in any convenient arrangement, the only proviso being that coils L<sub>1</sub>, L<sub>2</sub> and L<sub>3</sub> should be separated by *at least* two inches and preferably fixed with their axes mutually at right-angles. A Paxolin baseboard could be used and solder-tags, each bent at right-angles, affixed with small nuts and bolts.

The transformer specified is the Rex LT700 output transformer, which is inexpensive and widely available through various advertisers. This is actually a push-pull type, but by using it in the following manner it becomes single-ended with a ratio of about 40:1.

On one side of the transformer appear two leads; on the other, three. The two leads are the output to the speaker, whilst the opposite three leads are the input from the receiver. The middle one of the three is disregarded, whereupon the two outside leads are employed for the primary connections.

The coil, L<sub>3</sub>, consists of 80 turns of 32 to 36 s.w.g. enamelled wire wound on a 1in length of  $\frac{1}{8}$ in

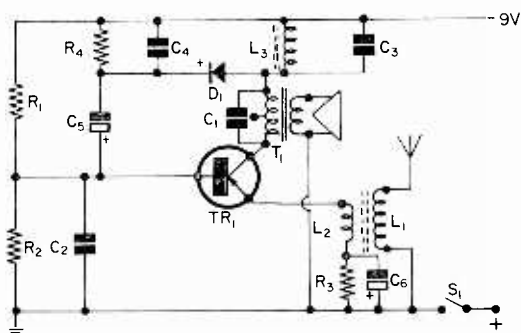

Fig. 1. The circuit of the "Unity" single transistor receiver

ferrite rod. Ferrite rod of this diameter is commonly sold as "surplus". If a thinner rod is used, a few extra turns may be necessary to compensate.

The coil is wound in a tight bundle on to the middle of a sleeve which may conveniently consist of a band of Sellotape, sticky side out. The free ends of the wire are simply twisted together to stop the coil unwinding. It should now be possible to slide the coil on its sleeve from one end of the rod to the other without too much difficulty. This is the method of tuning, and if the number of turns is correct, the signal will reach its loudest point a little before the coil itself reaches the end of the rod. It is best to start the coil with about six inches of wire to spare and to end with about the same amount of free wire. This is generous, and can be trimmed off later, after the coil has been finally adjusted.

The r.f. transformer, L<sub>1</sub>, L<sub>2</sub>, may be made in two different ways. For those who require a quick job, a suitable ready-made wire-ended r.f. choke may be obtained for the primary, and the few turns needed for the secondary coil wound directly on top of it. The r.f. choke specified for this is the Repanco CH1, and 16 turns of the same thin enamelled wire as is used for L<sub>3</sub> require to be wound neatly on to the *middle* of the existing coil. The ends are twisted together and prepared for soldering. The 16 turn winding is the secondary, and connects to R<sub>3</sub>, C<sub>6</sub>, and the emitter of the transistor.

An entirely home-made r.f. transformer may be constructed for a few pence in the following manner. Another 1in length of  $\frac{1}{8}$ in ferrite rod is taken and the secondary coil, consisting of 10 turns of 32 to 36 s.w.g. enamelled wire is wound directly on to the middle. With the free ends laid flat against the rod, this winding is covered with a band of Sellotape, sticky side down, to secure it. On top of this goes the primary coil, L<sub>1</sub>, this employs the same gauge wire and consists of 200 turns wound in as narrow a bundle as possible. Since the number of turns is large, some care is needed to keep the turns tight, but a coil only  $\frac{3}{8}$ in wide is fairly easy to achieve. This coil is then secured and finished off.

The transistor used will probably be determined by what the constructor happens to have on hand. An Ediswan XB103 is specified because, on test, it

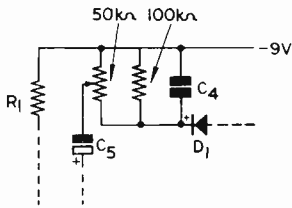

Fig. 2. Adding a volume control.  $R_4$  is replaced by a  $50k\Omega$  potentiometer (log track) with a  $100k\Omega$  fixed resistor in parallel

gave better results than the others tried. It is roughly equivalent to the OC71, NKT223, or GET113. Amongst the others tried, including OC70, OC72, OC76 and OC81, there was more difference in performance between individual transistors than between one type and another, so the choice is evidently a broad one. The constructor may, of course, be prepared to check other types than those mentioned here.

The speaker required is a high-gauss, low-impedance (3 to  $5\Omega$ ) type with *as large a diameter as possible*.

The prototype was built around a venerable 8in speaker stripped from a defunct receiver, and the whole circuit of the "Unity" was designed simply to find out what could be achieved in terms of output, using one transistor only and the smallest possible outlay of cash. Given a speaker of this diameter, it is surprising how loud 45 milliwatts can sound. The writer has actually to use a volume control after dark to prevent slight overloading of the audio stage.

### Final Adjustment

When the set has been completed, connect the aerial and earth. Ensure that the battery is connected with correct polarity and switch on. Slide coil  $L_3$  along the ferrite rod until the Light Programme "peaks" at the loudest point. If this happens with the coil at the mid-point of the rod, add a few turns to the coil and try again until the programme peaks with the coil off-centre. If peaking occurs with the

coil partly off the end of the rod, remove a few turns to correct this.

If no noticeable peaking takes place (and this *can* happen with a very long aerial) connect the aerial to the set via a small-value capacitor (say  $200pF$ ) instead of directly.

When the coil is correctly adjusted, it should be secured in place. If a Paxolin baseboard is used, the coil may be stuck to this with a strong glue.

Apart from shortening the leads of  $L_3$ , if necessary, the receiver is then ready for use.

### Volume Control

In favoured areas a volume control may be needed to prevent overloading. Fig. 2 shows the necessary circuit changes. The fixed resistor  $R_4$  is replaced by a variable component with the negative plate of  $C_5$  connected to the wiper. Since  $33k\Omega$  volume controls are virtually unobtainable, a  $50k\Omega$  volume control with a fixed resistor of  $100k\Omega$  in parallel is used instead. This gives an effective  $33k\Omega$  load, which is about optimum. The potentiometer should have a log track.

### Consumption

The resistors  $R_1$ ,  $R_2$  and  $R_3$  are chosen to give a collector current of about  $5mA$  with an average transistor. Output falls off fairly quickly below this current level and starts declining more gradually above  $10mA$ . Naturally a few transistors, especially the "surplus" kind, will give collector currents outside these limits.

Constructors who have access to a milliammeter may care to insert this in one of the battery leads and adjust  $R_2$  until about  $5mA$  is recorded.

### Using an Earpiece

Since the output of the "Unity" is at low impedance it may be connected directly to one of the low-impedance earpieces which are sold (very cheaply these days) for connection to pocket superhets, tape recorders, etc. These are very small and robust and reproduce with good tone. The receiver may then be used as a bedside set which does not disturb other people.

## Club Events

### 12th International VHF Convention

Convention Secretary: F. Green, G3GMY, 48 Borough Way, Potters Bar, Middx.

**2nd April**—The convention will take place at the customary rendezvous, The Kingsley Hotel, Bloomsbury. A full lecture programme is planned for the afternoon, the annual dinner taking place in the evening. In addition to commercial exhibits, there will be a special display of home constructed equipment in competition for the "1962 VHF Committee Cup". Applications for tickets

should be sent to the Convention Secretary, 4s. 6d. (afternoon session) or 30s. (afternoon and evening sessions).

### Mid-Warwickshire Amateur Radio Society

Hon. Sec.: K. J. Young, 180 Northumberland Court, Leamington Spa.

**April 4th**—Visit to Leamington Telephone Exchange.

**April 18th**—Frequency Modulation, R. J. Ward.

# Finding the Velocity of Sound in Air Experimentally

By H. LEWIS

*A simple and easily carried out experiment which can increase our understanding of one of the basic attributes of sound. The technique described here could be adapted, also, to find the velocity of sound in media other than air*

**S**OUND IS PROPAGATED BY WAVES WHICH CONSIST of alternate compressions and rarefactions. If a sine wave is used to drive a loudspeaker, the pressure of the air at any instant is shown in Fig. 1. The pressure at any point will of course vary with time, and a microphone (or a loudspeaker connected to work as a microphone) will respond to the changes in pressure by giving an output voltage which is a replica of the voltage supplied to the first loudspeaker, except that (assuming equal impedances) the magnitude of the second voltage will be less than that of the first. This is due to attenuation in the air, inefficiency in the loudspeaker and microphone (or second loudspeaker), and to the fact that not all of the transmitted sound is picked up at the receiving end. There will also usually be a phase difference between the two voltages, due to the time taken for the sound to travel.

## Both Voltages in Phase

If the distance between transmitter and receiver is one wavelength apart, then both voltages will be in phase as the output voltage is delayed one wavelength. The result is that there is effectively no phase difference. With simple equipment, however, the measurement of this distance would be extremely difficult to perform accurately due to the size of the loudspeaker. A wavelength—the distance along which a cycle of sound is distributed at a given instant—may be found more accurately in another way.

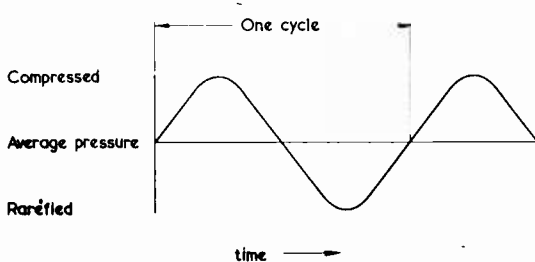

Fig. 1. Graph showing air pressure with sine wave drive to the loudspeaker

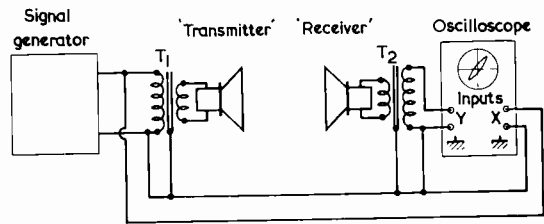

Fig. 2. Oscilloscope method of finding wavelength. The transformer cores are earthed to minimise hum pick-up

Suppose the position of the receiver relative to the transmitter is adjusted to give a certain phase difference between the transmitter input and receiver output voltages. If one loudspeaker is then moved away from the other, the phase difference will change until it becomes the same as it was before moving. The distance moved is a wavelength.

The relationship between velocity ( $v$ ), frequency ( $f$ ), and wavelength ( $w$ ) is:  $v = fw$ . Therefore, as both the frequency and wavelength can be found, the velocity of sound may be calculated. A signal generator may be used as a sine wave source to drive the transmitting loudspeaker, the frequency being given by the tuning scale of the generator. The wavelength can then be obtained as just described, whereupon all that remains is to find a means of measuring the phase difference between the two voltages.

There are two good methods which are suitable for this purpose. One of these methods is to use an oscilloscope connected to show Lissajous figures. The other method is to use an a.c. voltmeter.

## Oscilloscope Method

The circuit diagram for the oscilloscope method is shown in Fig. 2. The loudspeakers may be small and cheap. Transformer  $T_1$  should match the "transmitter" loudspeaker to the signal generator output. So far as the "receiver" loudspeaker is concerned, the higher the ratio of  $T_2$  the better as this gives a voltage step-up before application to

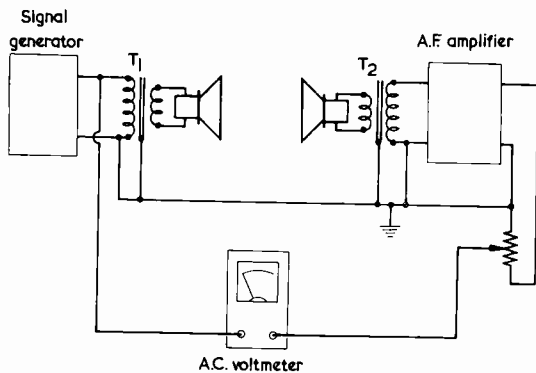

Fig. 3. Finding the wavelength with the aid of an a.c. voltmeter

the oscilloscope. If the signal generator will not give enough power to drive the loudspeaker sufficiently, a simple a.f. amplifier may be interposed.

Connect the output of the "receiver" loudspeaker to the vertical (Y) input of the oscilloscope, and the signal generator to the horizontal (X) input. Support the loudspeakers firmly at the same height.

Set the signal generator frequency to 500 c/s, and adjust the output for a suitable volume. Move one loudspeaker until a diagonal line going from the bottom left corner to the top right corner of the screen is obtained, adjusting the oscilloscope gain controls until this line makes an angle of 45° with the horizontal. This diagonal line is the trace obtained from two signals of equal frequency and with no phase difference between them<sup>1</sup>.

Measure the distance between the loudspeakers in feet. Move the loudspeakers further apart until

<sup>1</sup> The straight line trace, as opposed to an ellipse or a circle, is given for phase differences of 0° or 180° only, and its direction, from bottom left to top right or bottom right to top left, will depend in the present arrangement on possible phase inversions introduced by amplifiers, transformers and speaker connections. Two in-phase voltages applied directly to X<sub>1</sub> and Y<sub>1</sub> plates, with X<sub>2</sub> and Y<sub>2</sub> common, give a line from bottom right to top left. Alternatively, the common practice of connecting the plates so that positive input voltages cause deflection to the right and upwards results in a line from bottom left to top right with in-phase voltages. In the present experiment, it does not matter whether the reference point corresponds to 0° or 180° phase difference.—EDITOR.

this diagonal is again obtained, *going in the same direction*, and measure the distance between the loudspeakers again. Subtract the first distance to find the distance moved, i.e.  $w$ . The velocity of sound in air is then obtained from  $v=fw$ .

The velocity of sound in air is known to be approximately  $(1,054+1.1 t)$  ft per second, where  $t$  is the temperature in °F. Thus in a room at 70°F, the velocity of sound is 1,131ft/sec.<sup>2</sup> The accuracy of the results may be computed: percentage error =  $\frac{A-B}{B} \times 100$ , where A is the experimental value

and B the known value.

The author's experiment gave quite accurate results. Using a frequency of 1,000 c/s, the error was about 2%. When the experiment was repeated with the signal generator at 500 c/s, the error was only about 0.5%. Note that the accuracy is considerably increased when a longer wavelength is involved.

### Meter Method

When two sine waves of equal amplitude and frequency are "added", the result is a sine wave with an amplitude ranging from twice the amplitude of the sine waves when these are in phase, to zero when the difference between the phases is 180°. This fact leads to a method of finding the wavelength of sound with equipment that almost every keen constructor has, i.e. an a.c. voltmeter and a simple "lashed-up" amplifier.

The drive to one loudspeaker is measured and the gain of the amplifier adjusted so that its output is the same. The circuit is then set up as shown in Fig. 3, and the spacing between the loudspeakers adjusted for minimum reading on the meter.<sup>3</sup> The distance between the loudspeakers is then increased until the reading is again at its minimum. The increase in separation is then the wavelength of sound. The subsequent calculations are the same as when an oscilloscope is used.

<sup>2</sup> Most references give the velocity of sound in air as 344 metres per second at 20°C (=68°F) and at sea level. This is 1,129ft per second, correcting to 1,131ft per second at 70°F.—EDITOR.

<sup>3</sup> Again, possible phase inversions could result in the minimum reading being given when both speaker signals are in phase. This will not affect the results given by the experiment.—EDITOR.

## EMI Tape Recorders for Audio Fair

Two models of professional tape-recorders—the BTR4 and L4—will be exhibited by EMI Electronics Ltd at the International Audio Festival and Fair at the Hotel Russell, London, W.C.1, from 14th to 17th April.

The BTR4 has features not previously found in studio tape recorders and is suitable for a wide range of applications, varying from studio sound and television broadcasting to scientific, industrial and medical research.

It was introduced last spring and has already been sold to Australia, Portugal, Greece, the Sudan, Rhodesia, Sierra Leone and Zambia as well as many U.K. TV and commercial recording studios.

It is available in half or full track monaural, two track stereo—the head block is easily changeable—and in console or rack mounted versions.

Variable spooling in either direction is provided, with automatic removal of the tape from the heads by retractable guides. Automatic action is governed by manual over-riding control which can be locked in the running position during spooling. The L4 tape-recorder is a portable battery-operated transistor model weighing only 10½lb, inclusive of the leak-proof, lead-acid rechargeable cells.

Other additional facilities include a choice of two speeds 7½ or 3½ i.p.s., remote control, press-button operation and mixing of two microphone inputs.

The L4's portability and simple operation make it ideally suitable for industrial noise measurement, medical research and a wide variety of other uses in science, industry and entertainment.



# Automatic Gramophone Cut-out Device

By C. J. Collister

*How to ensure that the record player amplifier gets switched off after the last record has been played*

THERE WERE CERTAIN MEMBERS OF THE AUTHOR'S family who, after putting on a record, used to forget all about it and go off to do something else. The result was a premature exhaustion of the amplifier valves and, of course, no decrease in the electricity bills. The device described in this article was adopted to combat this undesirable state of affairs.

The automatic switching circuit employed by the writer can be used with any single record gram deck which switches off the motor when the record has been played. It may also be used with any changer which similarly switches off the motor when the last record is finished. The process of switching off the motor sets in operation a timing circuit having a period of approximately seven minutes. If, during this period, the gram motor is not switched into circuit again (by the playing of a further record) an electromagnetic trip switch breaks the mains supply to the complete installation. When the amplifier and gram deck is required at a later time the trip switch may be reset by simply pressing a button, whereupon the equipment reverts to its previous condition and is ready for use again.

Fig. 1. The circuit of the automatic cut-out. The 6.3 volt and h.t. supplies are obtained from the amplifier.  $V_1$ ,  $RLY_2$  and associated components may be mounted on a small sub-chassis

The device may be used with any amplifier whose power supply is capable of providing an extra h.t. current of 8mA and an extra 6.3V heater supply of 0.3A for the delay valve, these being requirements which should be capable of being readily met in most instances. Extra current from the 6.3 volt heater supply may also be needed to momentarily energise the electromagnetic switch. The amplifier should, preferably, have a double-wound mains transformer offering isolation from the mains supply. If an amplifier of the a.c./d.c. type having a live chassis and a series heater chain is employed, it will be necessary to provide a separate heater transformer for the delay valve. There is a common connection between the delay circuit h.t. negative line and the amplifier chassis, with the result that, when a live chassis amplifier is used, all the delay circuitry becomes similarly live and full precautions must be taken to prevent accidental shock. None of these problems arise with an amplifier having an isolated chassis.

The device uses two relays and the electromagnetic trip switch just mentioned (which, in the writer's case, was home-constructed) and it is assumed that the reader has sufficient experience to be able to bring suitable relays and a suitable switch into correct operation for the circuit. Most general purpose relays can be adapted for use and, for this reason, relay types are not specified. One of the relays is energised directly by the mains supply and this can consist of an a.c. operated type with, if necessary, a series resistor to limit coil current, or of a conventional d.c. type whose coil is connected to the mains by way of a rectifier, smoothing capaci-

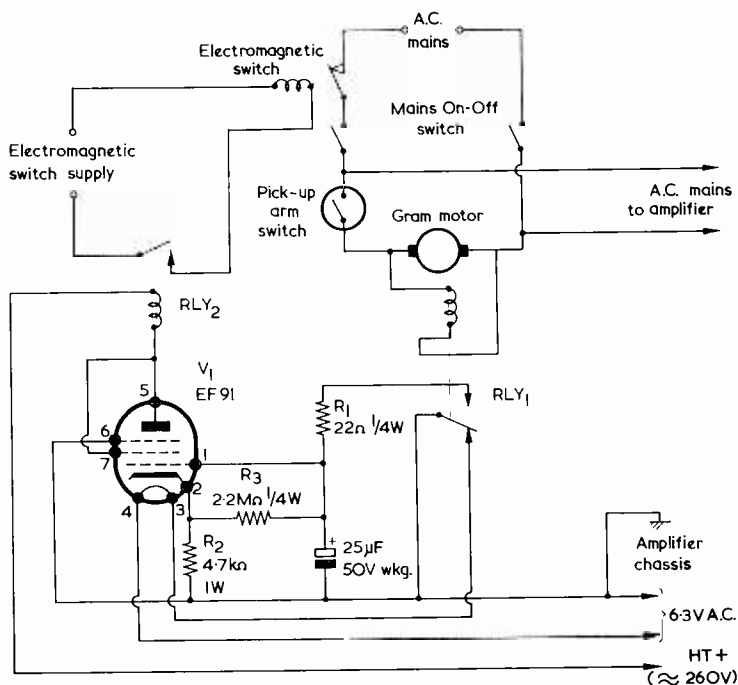

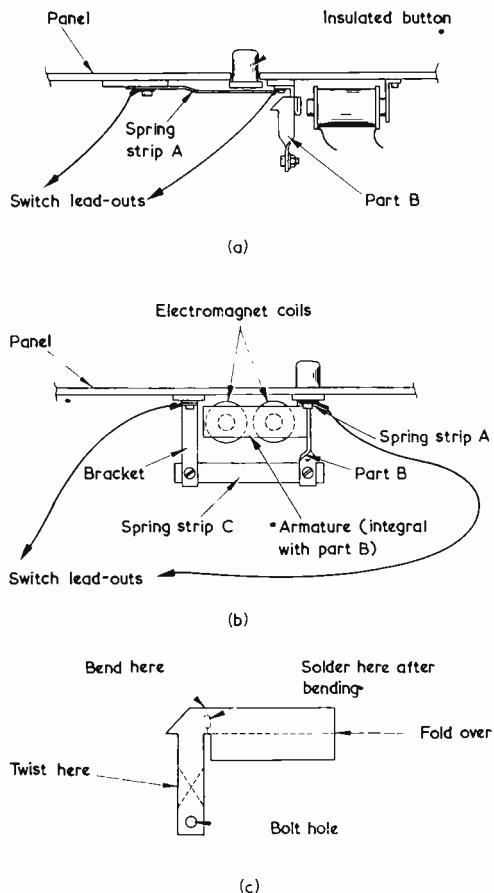

Fig 2 (a). Side view, showing the basic action of the electromagnetic switch  
 (b) Another view of the switch. In this diagram the secured end of strip A is towards the reader  
 (c). Part B, before it is bent and twisted to its final shape

tor and current limiting resistor. In the circuit the relay coil is shown connected directly.

### The Circuit

The circuit of the delay device is shown in Fig. 1. In this diagram the mains input is applied, via the normally-closed contacts of the electromagnetic switch, to the main on-off switch fitted in the equipment. The mains supply is then passed to the amplifier and to the gram deck. When records are being played, the mains supply is applied to the gram motor also.

Connected across the gram motor is the coil of relay RLY<sub>1</sub>, and this is in the energised condition whilst the gram deck is in use and its motor is running. The changeover contact of RLY<sub>1</sub> keeps electrolytic capacitor C<sub>1</sub> short-circuited via the 22Ω resistor R<sub>1</sub>. At the same time, it prevents the 6.3V supply being applied to the heater of V<sub>1</sub>.

When the record on the turntable (or the last record in the case of a changer) has been played the supply to the gram motor is cut off and RLY<sub>1</sub> becomes de-energised.\* Its changeover contact then moves to the de-energised position, whereupon it takes the short-circuit off C<sub>1</sub> and completes the heater supply for V<sub>1</sub>. V<sub>1</sub> now commences to warm up.

After a period V<sub>1</sub> passes current, whereupon a bias voltage appears across R<sub>2</sub>. The grid of V<sub>1</sub> is, however, at h.t. negative potential due to the discharged capacitor C<sub>1</sub>, and the valve does not pass sufficient current to energise RLY<sub>2</sub>, whose coil is in its anode circuit. Capacitor C<sub>1</sub> now commences to charge, via R<sub>3</sub>, towards the potential at the cathode. However, as C<sub>1</sub> charges and its upper plate goes positive, the valve passes an increasing current, with the result that the cathode goes positive also, although to a lesser degree. The overall result is that there is an appreciable delay before the valve passes sufficient anode current to energise relay RLY<sub>2</sub>. With the prototype, this delay was of the order of seven minutes after the initial de-energising of RLY<sub>1</sub>.

When RLY<sub>2</sub> energises, its contacts complete the circuit to the coil of the electromagnetic switch, which then trips and cuts off the supply to the equipment. The latter may, then, only be brought into use again by resetting the trip switch.

### Further Points

As will be seen from Fig. 1, the delay circuit employs an EF91 with screen-grid and anode strapped to form a triode. With the prototype the initial current through the relay was 1.5mA after the valve had warmed up, this increasing slowly to 8mA some seven minutes after the de-energising of RLY<sub>1</sub>. Longer or shorter timing periods may be obtained by variations in the values of R<sub>3</sub> and C<sub>1</sub>. It is necessary for C<sub>1</sub> to be a good quality component having a low leakage current. Relay RLY<sub>2</sub> was adjusted to energise at 8mA.

In the writer's equipment, and as shown in Fig. 1, one side of the 6.3 volt heater supply was common to the chassis of the amplifier. The delay circuit should still function satisfactorily if the heater supply obtained from the amplifier is centre-tapped, as this will merely result in the negative supply line associated with the delay circuit having an added a.c. potential of 3.15 volts with respect to the amplifier chassis. This should not upset the operation of the delay circuit.

The 22Ω resistor, R<sub>1</sub>, is included to limit the current flowing through the contacts of RLY<sub>1</sub> should this become energised whilst capacitor C<sub>1</sub> holds a charge. In consequence, heavy discharge currents at the contacts are eliminated, and their life is extended.

\* Some changers, including in particular those which incorporate a heater tap in the motor winding, have the motor running all the time, regardless of whether records are being played or not. However, such changers can, in many instances, still be used for the device described here, because they are frequently fitted with a switch which opens when the last record has been played, this switch not being wired into the motor circuit. Such a switch can be used to apply the mains supply to RLY<sub>1</sub> in Fig. 1. The existing motor wiring in the deck should not, of course, be disturbed.—EDITOR.

### Electromagnetic Switch

The electromagnetic switch has a trip action, and a suitable ready-made component could be of the type found in model railway transformers whose function is to minimise the risk of burn-out through overloading. However, the author's switch was home-constructed, and it was made up in the manner shown in Figs. 2(a) and (b).

The method of operation is quite simple. Under normal conditions, spring strip A is pressed down, whereupon its free end latches under the projection of part B. The lower end of part B is mounted on spring strip C, which provides slight forward pressure. When strip A is depressed a circuit is completed by way of the three parts, A, B, and C. If a current is applied to the electromagnet winding, part B is attracted to its core, strip A releases, and the circuit is broken. The switch may be restored to its previous condition by pressing the insulated button, whereupon strip A once more latches under the projection on part B.

As may be seen from the view in Fig. 2(b) the electromagnet employs two coils, and these appear in the familiar horseshoe magnet assembly associated with electric bells. Indeed, a very efficient electromagnet may be provided by removing the coils from an electric bell. In the writer's model the electromagnet was provided by winding some 200 turns of 28 s.w.g. enamelled wire on each leg of a large sawn-off iron staple. Care should be taken to connect the two coils such that opposite magnetic poles appear at the core ends presented to part B. The writer's electromagnet was powered by 6.3 volts a.c. taken from the heater supply of the

amplifier. The current drawn by the electromagnet coil was not measured as it flows only for the very short period of time needed to operate the switch, and it was felt that this momentary flow of current would not cause any serious overload of the transformer.

The spring strips were made from suitably trimmed razor blades, filed as required to expose the actual metal, and provided with notches at the ends to take mounting bolts.

Part B was made from 20 s.w.g. tinplate. This was cut out to the shape shown in Fig. 2(c), after which it was bent and twisted to the appearance given in Figs. 2(a) and (b). It will be seen that the folded-over section of part B forms an "armature" consisting of two thicknesses of tinplate, which is attracted to the electromagnet.

The gauge of tinplate employed provides adequate strength, but it is advisable to give added rigidity by applying a blob of solder to the inside of the 90° bend where the "armature" section joins the remainder of part B.

If a switch of this nature is employed, and is run from the heater supply of the amplifier, it is important to ensure that it is completely reliable in operation. Should it not release immediately, a heavy current may be continuously drawn from the amplifier heater supply, with a consequent risk of damage. It is also essential, of course, to ensure that all parts and mounting bolts, etc., which are at mains supply potential are completely insulated so as to obviate the risk of shock to people using the equipment.

---

## Solid State Microwave Oscillators

**I**N SATELLITE RESEARCH AND CERTAIN OTHER fields there is a great need for light-weight solid state oscillators which can be used at microwave frequencies. At the moment klystrons and travelling wave tubes are usually used, but these tubes together with their power supplies tend to be quite heavy by modern standards. The solid state oscillators which have already been produced experimentally can provide a maximum output power of some milliwatts at frequencies up to about 1 Gc/s (1,000 Mc/s). The volume of one of these devices is only about one hundredth of a cubic centimetre.

One type of device being investigated by Standard Telephones and Cables Ltd. at Harlow employs

the Gunn effect (discovered by J. B. Gunn in 1963) in which an electric field applied to low resistivity gallium arsenide causes the charge carriers in the material to travel in regions known as domains. In these devices a layer of gallium arsenide about 15 microns in thickness is deposited on a high resistivity gallium arsenide substrate. An epitaxial construction is used, since this enables heat to be removed from the device at a satisfactory rate. The devices can be used as oscillators, amplifiers and in pulse circuits. It is expected that the maximum power obtainable from this type of device will be raised as research and development proceeds.

# In Your Workshop

*As readers may be aware, events tend to get a little hectic in the Workshop on occasion. Such a situation occurs at the start of this month's episode, but things soon calm down under the soothing influence of tea, together with a discourse by Smithy the Serviceman, for the benefit of his able assistant Dick, on the basic circuits employed in domestic valve tape recorders.*

"**H**EAR THIS! HEAR THIS!"  
Smithy groaned inwardly as he once more attempted to concentrate on the faulty television receiver on his bench.

"Testing, testing!"  
The Serviceman glanced down at his watch. One comforting thought broke through the gloom: it was very nearly tea-break.

"One, two, three, four. One, two, three, four!"

It had been a difficult morning. His assistant's first job had been the repair of a record player which tended to go into occasional instability at high volume levels, whereupon Dick had enthusiastically proceeded to test it at full volume with the Rolling Stones' latest l.p. After a nerve-racking quarter of an hour Smithy had, reluctantly, to privately admit the wisdom of Dick's choice of disc when one truly shattering bass guitar chord caused the fault to unexpectedly come on. The occasionally microphonic valve which was giving the trouble suddenly produced a tortured acoustic howl having such undertones of wretchedness and misery that even the clattering of Dick's screwdriver handle against his bench in time to the lunging rhythm was momentarily stilled. The stricken valve slowly faded into its final demise and blessed peace descended upon the Workshop, but only for the period needed by Dick to find a replacement and plug it into the player. He then checked the new valve, again at full volume, with the other side of the Rolling Stones' l.p.

Optimistically, Smithy had hoped that the next job chosen by his assistant, a somewhat elderly mains table radio, would result in an ambient noise level which was at least several decibels below the threshold of pain. Unfortunately,

his expectations were quickly shattered when Dick found that the primary of the mains transformer in the receiver had burnt out, and that the only suitable replacement available had different mounting centres. Admittedly, there was a brief respite whilst Dick, wearing a direful scowl indicative of intense concentration, marked out and centre-popped the four new holes required; but this was quickly followed by the selection of a No. 10 2BA clearance drill from Dick's stock, the purposeful plugging in of the Workshop electric drill, and the scream of riven metal as the bit battled manfully against the solid mild steel of the receiver chassis. A subsequent brief cessation of labour must be recorded, this taking place at the start of the third hole when Dick, vigorously sucking a finger, retired to the First Aid box. The proceedings were, however, soon resumed with the injured member heavily covered with Elastoplast. A student of cause and effect could find an intriguing chain of circumstances here: samples of Dick's blood were distributed all round the neighbourhood in the cabinets of radio and television receivers on whose chassis he had carried out drilling operations; these samples were due, in their turn, to the fact that Dick's habitual approach towards drilling consisted of applying maximum pressure to the work; this approach was virtually a conditioned reflex which, in its turn, derived from the fact that all Dick's drills were extremely blunt.

## The Last Straw

A mortal purgatory cannot exist for ever and the long-suffering Serviceman noted with relief the eventual transfer of the receiver, with its new mains transformer safely installed, to the "Repaired" racks. He had observed that Dick's next choice was a fairly large valve tape recorder of the domestic category and, once more optimistically, he had hoped that this repair would be a little less distressing for the nerves than the previous two had been. Indeed, the affairs of the Workshop had proceeded more or less normally for a time as Dick probed inside the recorder. Glad of the respite, Smithy had filled and switched on the Workshop kettle for the morning's tea-break. He had, in fact, become almost completely immersed in the repair of the television receiver on his bench when Dick's voice, applied to the tape recorder microphone, broke into his thoughts.

By now Dick had completed his test recording. He stopped the machine, ran the tape back, made a

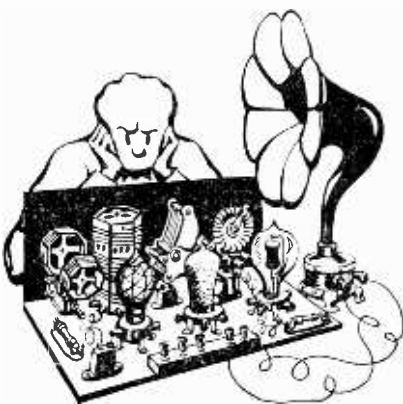

few adjustments, and set it running again. The air was immediately filled with the sound of the Rolling Stones, reproduced at full volume level. Even Smithy was momentarily dumbfounded at this unexpected development but his ire was, at long last, commencing to rise. Just as he was about to shout across the Workshop to his assistant, the Rolling Stones ceased as abruptly as they had started. The noise of sonorous breathing came from the tape recorder.

"Hear this!" thundered the recorder. "Hear this!"

The voice, although badly distorted, was obviously Dick's.

"Testing, testing!" blared the recorder.

At this instant the Workshop kettle came to life and a low whistle became audible in the background.

"One, two, three, four," trumpeted the recorder. "One, two, three, four!"

Smithy again drew breath to shout at his assistant, but the Workshop kettle was now pouring forth great volumes of steam and its ear-splitting shriek, combined with the roaring output of the recorder, would have made Stentor himself inaudible.

"One, two, three, four. One, two, three, four," bellowed the recorder.

"Testing, testing, testing! All systems go, all systems go! Testing, testing, testing! Roger, roger, wilco and out!"

The voice from the recorder ceased, to be abruptly replaced by the Rolling Stones once more.

It was at that instant that the Workshop came abruptly to a stop. All the lights went out and the recorder became silent, its spools slowly coming to rest. The whistle from the Workshop kettle gradually reduced in volume until this, too, became silent.

All was tranquil.

Dick turned round with an expression of mild surprise.

"Is anything," he enquired curiously, "up?"

"Is anything up?" exploded Smithy, from his station at the Workshop main switch. "Is anything up? No, of course there's nothing up. It's just that, after the events of this morning, I felt my ear-drums were finally going, that's all. Nothing serious, of course."

"Oh," said Dick doubtfully. "Do you mean I was doubting that tape recorder too loud or something like that?"

"Something like that," agreed Smithy wearily. "Anyway, for goodness sake turn the blamed thing off, and let's have a break. If ever I needed a spot of tea, it's now!"

After having carefully watched Dick turn off the recorder, Smithy re-applied the mains. The lights came on again and the kettle soon recommenced its whistle. It was not long before Smithy's battered tin mug was alongside him, its contents ready to ease his overwrought nerves.

"I suppose," proffered Dick, "that I was making a bit of a noise with that recorder."

"You were making," Smithy corrected him, "a cacophonous *din* with that recorder. What is more, you've been making a cacophonous *din* all the morning. Also, how on earth is it that that tape recorder was playing exactly the same pop music that you were previously playing on the record player?"

"I should imagine that the people who have the recorder put it on the tape themselves," replied Dick. "Which only goes to show that they have the same advanced taste in music that I have!"

The instinct of the service engineer, always dominant in Smithy, caused a gleam of interest to appear in his eye.

"Was that the tape which was on the machine when it came in?"

"That's right," confirmed Dick.

"Then," said Smithy immediately,

"I should have a look at the bias circuit before you go any further. Despite the fact that you'd set the volume so high that half the sound must have come to me by bone conduction, I was still able to note that the quality of reproduction of the pop music was quite good during the brief periods when the output stage wasn't grossly overloaded. Furthermore, this previous recording was completely wiped off when you switched on to record your own little testing bit, which means that the erase circuits are coping O.K. as well. At the same time, the recording of your own voice was noticeably more distorted than the pop music. I would say, therefore, that there's a definite possibility that, since the previous recording of the pop music was made, the bias circuit has gone up the wall."

#### Tape Recorder Basics

"I don't get you," replied Dick puzzled. "The ticket with the recorder said that it was distorting on 'record', and one of the first things I did was to check the bias circuits for all the valves."

"I'm not talking about valve bias," said Smithy irritably. "I'm talking about bias for the record-playback head."

"Does that require bias, too?" asked Dick innocently.

"Of course it does."

There was silence for a moment, and Smithy glanced doubtfully at his assistant.

"You don't," he pronounced, "seem to know very much about tape recorders."

"I don't," replied Dick.

"Well, you *ought* to. We've had quite a few of them in here in the past."

"I know we have," said Dick, the memory of a long suppressed grievance colouring his voice, "but you always snaffle them yourself. All *I* get are the mechanical snags to clear up. I was hoping to have a really good go at the electronics side of that recorder this morning."

"You wouldn't," commented Smithy unkindly, "have got very far with it if you don't even know what the bias circuit for the record-playback head is meant to do. It looks as though I'd better give you a bit of gen on tape recording during this tea-break, otherwise you'll be just as much in the dark afterwards as you are at present."

Smithy paused for a moment, and sipped his tea thoughtfully.

"Let's see now," he said reflectively. "What would be a good approach? Ah, yes! If I'm going to give you some information on tape recording, the best thing for me to do will be to tackle the subject from the point of view of domestic valve recorders of the type you've got on your bench right now. Nearly all the domestic valve recorders you'll be called on to service these days have the same basic stage line-up, and they just differ in terms of circuitry. Also, they provide an easily absorbed example of simple tape recorder principles. Perhaps you could bring over the service manual of that recorder."

Obligingly, Dick picked up the service manual and placed it beside Smithy. He returned for his stool, whilst Smithy opened the manual at the circuit diagram.

"This circuit," commented Smithy, as Dick settled himself alongside him, "is entirely typical of the sort of thing you encounter in practice with recorders of this type. Now, despite your professed ignorance of tape recorders, I should be able to assume that you know how a tape recorder record-playback head works, shouldn't I?"

"Oh, definitely," replied Dick promptly.

"The tape recorder record-playback head is basically an electromagnet having a narrow gap across which the tape passes. (Fig. 1) Varying currents in the coil of the head then magnetise the tape

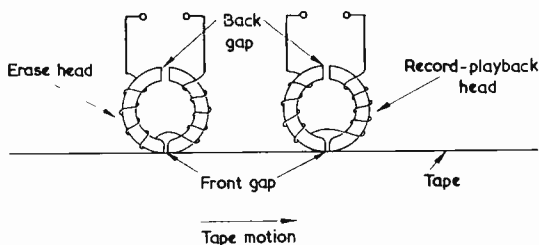

Fig. 1. The conventional domestic tape recorder has an erase head and a record-playback head. Each head is basically an electromagnet having a gap at the front across which the tape passes. There is also a gap at the back which assists, amongst other things, in reducing induced hum in the head

accordingly. When the tape is played back it's run across the gap again, whereupon its magnetisation causes currents to be induced in the head coil which are similar to those which were applied to the coil in the first place. If these currents are amplified you can then reproduce the original signal."

"Good," said Smithy, "and we needn't bother to go any deeper than that at the moment, apart from repeating that the single head can be used for recording and for playback. This is done in the domestic recorders we're now going to consider."

Smithy took a sip at his tea. The soothing effects of this beverage, combined with the fact that he was now holding forth on a subject in which he had a considerable amount of interest, were causing him to completely forget the earlier trials of the morning.

"Let's next," continued Smithy, "see what's required in the nature of amplification to play back the recorded signal on the tape. In practice, we will find that quite a high degree of amplification is needed. One of the more frequently encountered a.f. amplifier line-ups in a domestic recorder switched to 'playback' consists of the two triodes of an ECC83 followed by the triode and pentode of an ECL82 or ECL86." (Fig. 2 (a).)

"Blimey," said Dick, impressed. "That's three triodes followed by a pentode output valve. You should get stacks of gain out of that little lot!"

"You do," agreed Smithy. "And don't forget, also, that the ECC83 is a high gain double triode. An alternative line-up you may encounter in some recorders employs an EF86 at the input, followed by the two triodes of an ECC83 and, say, an EL84 output valve." (Fig. 2 (b).)

"Phew," breathed Dick, "that's more again. A pentode, two high-gain triodes and an output pentode!"

"I'd better point out," interjected Smithy hastily, "that not all of the available gain is used. Some of the gain is lost because frequency equalising circuits are introduced, usually around the second valve in the line-up, to give a specific frequency response for the overall amplifier. These circuits are normally of the negative feedback variety and so the full gain of which the valves are capable is not realised. Nevertheless, there's still a considerable amount of amplification and it results in the input circuit being particularly susceptible to hum, noise and valve microphony. Whenever you're probing around at the input circuits of a tape recorder you want to be careful not to move components and wiring about too much

in case you accidentally cause an increase in hum pick-up."

Smithy took a further sip at his tea.

"Well now," he said, "that's the basic amplifier set-up for playback. Let's next see what's needed for recording. Now, the usual sort of microphone you get with these domestic tape recorders is a crystal type which offers a relatively high output at high impedance. No microphone transformer is required, and the microphone input goes straight to the grid of the first valve. For the sake of economy you obviously want to try and use the same a.f. amplifier valves for recording as you do for playback, and the practical solution consists of using the first three valves of the playback amplifier line-up we've just discussed. A typical recording amplifier chain then consists of the two triodes of an ECC83 followed by the triode section of the ECL82 or ECL86. Or, working from the second playback amplifier line-up I mentioned just now, it could consist of an EF86 followed by the two triodes of an ECC83." (Figs. 3 (a) and (b).)

"There's something wrong here," protested Dick. "The record-playback head is only being driven by a triode voltage amplifier."

"I know it is," agreed Smithy. "And, what's more, it will be driven by way of a resistor of about 100kΩ to 200kΩ inserted in series."

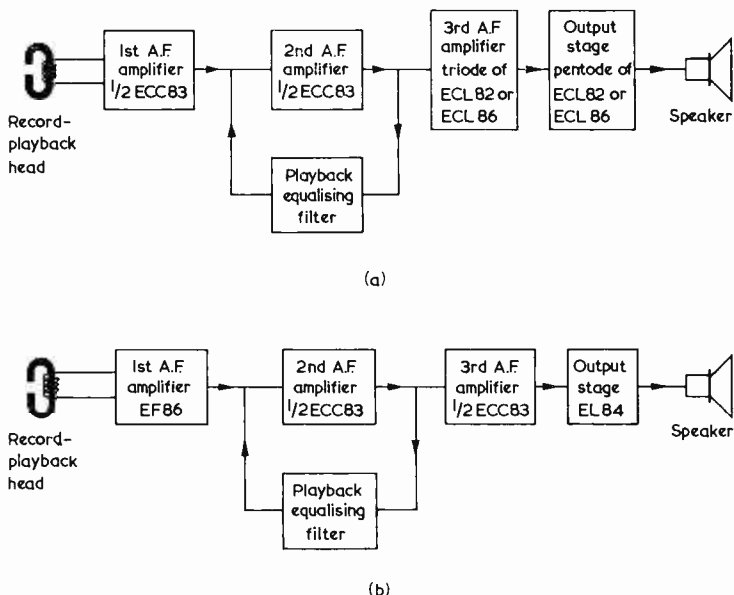

Fig. 2. A high degree of gain is required for playback. Two typical line-ups are shown here, that in (a) employing an ECC83 and an ECL82 or ECL86, and that in (b) employing an EF86, an ECC83 and an EL84

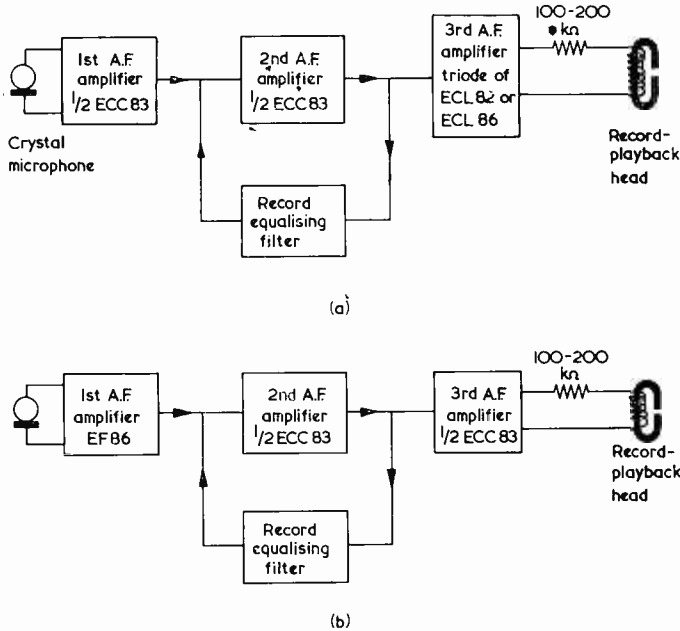

Fig. 3. The recording amplifier line-ups corresponding to the playback amplifiers shown in Fig. 2.

"Come off it, Smithy," snorted Dick indignantly. "How on earth are you going to pump any a.f. power into the recording head if you run it from a voltage amplifier valve and bung 100kΩ in series?"

"The answer to that," grinned Smithy, "is that you don't *have* to pump a great deal of power into the head. The record-playback heads used in domestic recorders can record very happily with a surprisingly small amount of a.f. power delivered to them and, as I say, sufficient can be provided in practice by a voltage amplifier feeding the head by way of a series resistor of some 100kΩ to 200kΩ."

"What's the series resistor for?"

"To give what is described as 'constant current drive,'" replied Smithy. "The idea is that the series resistor should have a value considerably higher than the impedance of the head at all the frequencies to be recorded, with the result that virtually the same current flows in the head for any one signal amplitude, regardless of its frequency."

"What about the head connections on playback?" queried Dick. "You didn't say anything about series resistors then."

"That's rather a different kettle of fish," replied Smithy. "When the record-playback head is used for playback, it just connects direct to the grid and cathode circuit of the first valve in the amplifier chain.

However, now that you've mentioned the input circuit, there's another little point I want to make about this

part of the recorder. Since recorders of the type we're referring to here normally use crystal microphones on 'record', the grid leak for the first a.f. amplifier has to have a high value. In practical recorders, it's normally of the order of 1MΩ to 10MΩ. This is a very high grid leak resistance, and it makes the input grid particularly susceptible to hum pick-up when the recorder is switched to 'record'. Which emphasises, once again, the need to avoid increasing hum pick-up by accidentally moving components or wiring at the amplifier input stage."

### Erase Oscillator

Smithy drained his disgraceful tin mug and held it up in a manner reminiscent of the Statue of Liberty. Without a word, Dick rose, took the mug from Smithy's hand, and replenished it at the Workshop sink. The custom was long established and unquestioned.

"There's an amplifier valve left out when you're recording," remarked Dick, as he settled himself once more on his stool. "If you only use the first three voltage amplifiers for recording, the output pentode isn't brought into circuit at all."

"That's a very good point," said Smithy approvingly, as he sipped at his tea. "As you say, the output

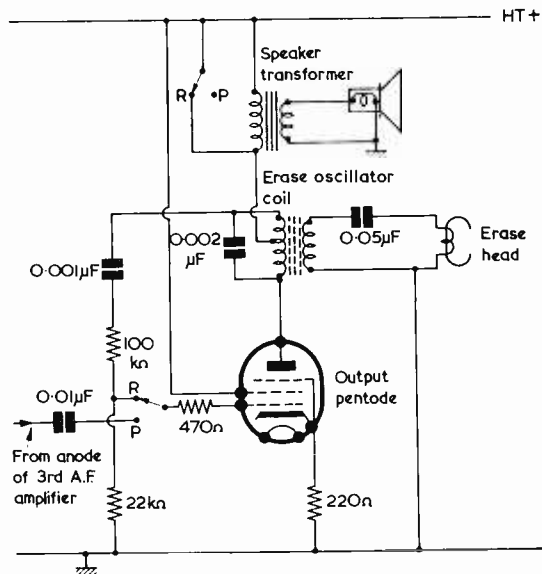
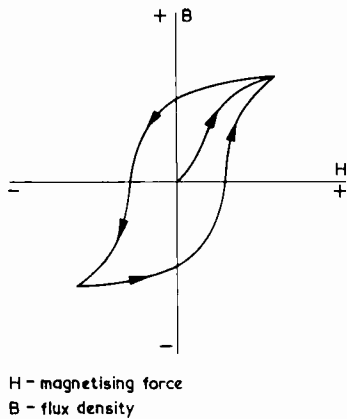

Fig. 4. A typical output/erase oscillator circuit for a domestic recorder, with representative component values. The tuned winding of the oscillator coil is in circuit all the time. When the circuit is switched to 'record', the primary of the speaker transformer is short-circuited and the pentode grid couples to the upper end of the oscillator coil tuned winding. The unbypassed cathode resistor assists in providing a good erase signal waveform. With some recorders, the oscillator coil consists of a single winding with taps for the earthy point and the erase head



pentode isn't needed in the recording amplifier chain at all. However, the designers of these domestic tape recorders are characterised by their fiendish and devilish cunning, and you can be quite sure that if they spot the odd valve going spare when you're switched to 'record', they're going to press it into service for another function. What happens, actually, is that, on 'record', the output pentode functions as the erase oscillator. The sort of circuit you get is of the same order as we've got in this service manual here. (Fig. 4.) When the switches in the circuit are set to 'playback', they couple the grid of the pentode to the anode of the preceding voltage amplifier, which will be the third in the amplifying chain we've just been discussing. The pentode then functions as a common-or-garden output valve driving the speaker. When you go over to 'record' the pentode grid is coupled to the oscillator coil, and the primary of the speaker transformer is short-circuited. The pentode then functions as an oscillator, running at some 50 to 60 kc/s. A winding on the oscillator coil feeds the erase head, which then provides the erase facility. Since the tape passes the erase head before it reaches the recording head, the erase frequency wipes off any previous recording that was put on the tape. The tape passing over the record head is then clean and ready to take a fresh recording."

"There's something here," commented Dick, "that I just don't get. To start off with, you drive the recording head from a voltage amplifier via a resistor of the order of 100 to 200 kc/s. At the same time, though, you drive the erase head from a dirty great output pentode without any series resistor at all. So far as I can see, the erase head is

coupled into the oscillator circuit quite tightly, too."

"There is," confirmed Smithy, "a pretty tight coupling. And you pump quite a good bit of power into

Fig. 5. A hysteresis loop. Hysteresis effects cause a recording on magnetic tape to be distorted unless a bias signal is also applied to the recording head

the erase head. In some of the earlier designs, indeed, the erase head used to get good and hot after it had been running for a while! The reason for the relatively high power is, quite simply, that it's necessary if you're going to get adequate erasure in practice. Apart from any other considerations, the erase signal must obviously be much stronger than the audio signals it is intended to wipe off the tape. Anyway, let's get on to the next point, which is that the erase oscillator also provides the bias for the record head."

"Is that the bias you were talking about just now?"

"The same," confirmed Smithy, "and its function is to overcome one of the basic problems which occur in tape recording. The problem is that if you try to record an alternating signal, on its own, on to a moving magnetic tape, the magnetisation of the tape follows a B-H hysteresis loop. Something like this."

Smithy pulled his notepad towards him and sketched out the loop. (Fig. 5.)

"Oh, I know that one," remarked Dick instantly. "That's the curve they try and thump into you when they're teaching you iron-cored transformer theory. The flux density in the iron doesn't directly follow the magnetising force provided by the coil current. Instead, it follows the route around the hysteresis loop."

"How is it," asked Smithy incredulously, "that, whilst you're normally as dim as the proverbial

N.A.A.F.I. candle, you occasionally produce immaculate little pearls of knowledge just like that one?"

"It's my innate intelligence," replied Dick promptly. "I don't waste my brains on everyday matters like other people do. I conserve them for really important things. Like hysteresis loops, for instance."

"Well," commented Smithy, gazing wonderingly at his assistant, "you've certainly got that one off pat. And it makes things a wee bit easier for me, too, because it enables me to point out that if, in getting an audio frequency signal on to the tape, it has to go through the considerable non-linearity of the hysteresis loop, the magnetic pattern on the tape is going to be a very distorted version of the signal applied to the coil of the recording head. This difficulty is overcome by applying a signal of about 50 to 60 kc/s to the record head in parallel with the audio frequency signal, this extra signal being known as the 'bias' signal. It has a higher amplitude than the a.f. signal, and it results in an almost perfect copy of the recording signal being produced on the tape. The full explanation of exactly how the bias signal achieves this result is complex, but a simplified way of looking at it is to say that the curve representing magnetic induction in the tape against signal current in the recording head exhibits most non-linearity for small signal levels, rather like the input-output curve for a Class B transistor output stage with insufficient base bias. The bias current applied to the recording head sweeps rapidly over the non-linear centre bit of the curve and goes way out to the more linear sections further away, whereupon the average of bias signal and audio frequency signal, in terms of magnetic induction, becomes very similar to the original audio frequency signal current in the recording head. I must emphasise, though, that this is a very simplified explanation."

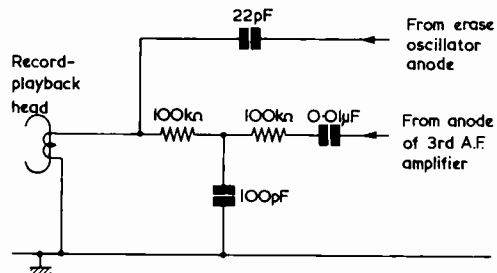

Fig. 6. One method of applying bias to the record-playback head. The basic principle demonstrated by this circuit will be encountered in all domestic recorders, although component values may vary widely from those shown here



"Fair enough," commented Dick. "I see that the bias signal has approximately the same frequency as the signal needed for erase. Is that why you draw the bias signal from the erase oscillator?"

"That's right," said Smithy. "A typical example of how this is done is given in the service manual we've got here. (Fig. 6) In this circuit, the anode of the erase oscillator valve is coupled to the record-playback head via a capacitor having the fairly typical value of 22pF. This value may seem small but don't forget that the bias frequency is quite high, and that the series capacitor will offer a low reactance as a result. In actual fact, at 50 kc/s a 22pF capacitor offers a reactance of about 120kΩ."

"There seem," Dick pointed out, "to be a few components in the circuit you haven't mentioned. There's a 100kΩ resistor next to the head and a 100pF capacitor."

"Ah yes," said Smithy. "They're in the circuit carrying the audio frequency to the record-playback head. Their function is merely to prevent the bias signal getting back to the anode of the voltage amplifier feeding the head, whereupon it might upset operating conditions there."

"Are there any other points to look for in this bias business?"

"Speaking in general terms," said Smithy, "there are just two more. The amplitude of the bias signal across the head is quite critical and some manufacturers fit a trimmer instead of a fixed capacitor in the coupling from the erase oscillator coil. You then set up the trimmer to give the required bias voltage across the head coil, as laid down by the manufacturer. The only other general point to make is that the bias and erase waveforms should, ideally, be pure sine waves. Quite a lot of care is taken in the design of the erase oscillator circuit to ensure that its output is as truly sinusoidal as it can be. If the erase waveform isn't sinusoidal, it's liable to leave noise on the tape."

### Complete Block Diagram

Smithy drew his notepad towards him once more.

"It will help, at this stage," he continued, drawing his pen from his top pocket, "to have a look at the block diagram for a complete recorder of the domestic type in the light of what we've discussed up to now. I'll just sketch out what I mean."

As Dick looked on, Smithy's pen moved briskly over the pad. The Serviceman soon completed his diagram. (Fig. 7.)

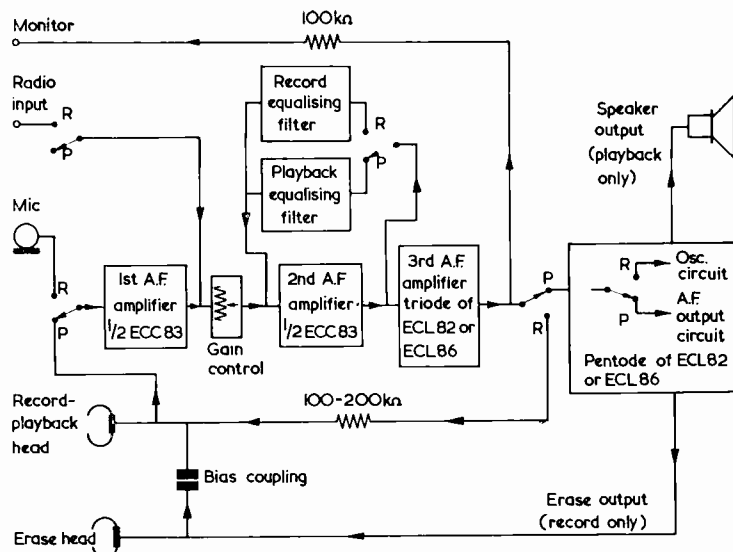

Fig. 7. Block diagram for a typical domestic recorder. The valve line-ups shown in Figs. 2 (a) and 3 (a) are assumed here, but the diagram is also representative of recorders employing the line ups of Figs. 2 (b) and 3 (b). The main variations likely to be encountered are in the input facilities other than microphone, and in the monitor output facility

"Here we are," he said, laying his pen on the bench. "We'll start off with the recorder set to 'playback'. On 'playback' you don't need an erase or a bias signal and all you have is a straightforward a.f. amplifier. The signal from the record-playback head just goes through the four valves in cascade and comes out of the speaker. A frequency correction filter is switched in at, typically, the second voltage amplifier and it provides the response needed for equalisation. This consists mainly of bass boost with, normally, a spot of treble boost as well."

"Bass boost?" queried Dick. "What do you need bass boost for?"

"It's necessary to have bass boost," replied Smithy, "because of the constant current signal which is passed to the head when you're recording. If losses at the head are ignored, equal amplitude a.f. recording signals result in equal degrees of change of magnetisation in the tape, regardless of frequency. But when the tape is subsequently pulled over a reproducing head, the equal changes in magnetisation at the higher frequencies cause higher voltages to appear across the coil of the head than do the equal changes in magnetisation at the lower frequencies. The effect is rather the same as you get with those little toy dynamos in which a coil rotates inside the two poles of a permanent magnet. As you rotate the dynamo

armature faster the voltage output increases, despite the fact that the changes of magnetisation, which are in this case given by a magnet of constant strength, remain the same."

"Blimey, Smithy," grinned Dick, "you're scraping the barrel a bit for examples, aren't you? Toy dynamos now!"

"The process I've just described," chuckled Smithy, "is surprisingly difficult to put over if you're not going to become too technical about it. At any event I hope I've explained why, assuming no head losses, a tape recorded under constant current conditions produces an output voltage, across the reproducing head, which increases as frequency goes up. Actually, the output voltage doubles as frequency doubles, or, to go all posh about it, you get a rise of 6dB per octave. Since the higher frequencies from the tape are reproduced by the playback head at a greater level than the lower frequencies, you have to apply bass boost in the amplifier to get everything bashed down flat again."

Smithy paused for a moment.

"As I've been saying," he resumed, "all this assumes that there are no losses at the head. In fact, of course, such losses are inevitable, and they will occur both during recording and reproducing. The main losses are at the high frequency end of the a.f. range. Because of these losses the effect given by the constant current recording technique, where the

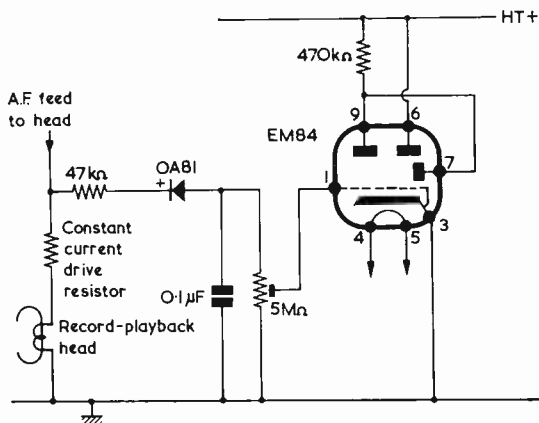

Fig. 8. A typical recording level indicator circuit using an EM84

output on playback increases with frequency, only holds good up to about 4 kc/s or so. After that, the losses take over, and a practical tape recorder of the domestic type is almost certain to have some treble boost in the playback circuits as well, in order to overcome them. Usually, though, the bass boost is a lot higher than the treble boost."

"Aren't we veering a bit?" asked Dick.

"Veering? In what way?"

"Well," said Dick. "we *did* start with that block diagram of yours."

"Perhaps we have veered a little," admitted Smythy. "But it was *you* who raised the query about the bass boost! Anyway, we've finished with the diagram so far as playback is concerned, so let's now change it over to 'record'."

Smythy remembered the mug of tea at his side. He picked it up and took a copious draught.

"Ah, that's better," he remarked, smacking his lips appreciatively. "Now, where was I? Oh yes, the block diagram on 'record'. Now, on 'record' the record-playback head is replaced, at the input of the amplifier, by a microphone. The signal is amplified by the first three voltage amplifiers, and is then applied, via the high value resistor to give constant current working, to the record-playback head. We also switch in a different equaliser circuit. This time, the function of the equaliser circuit is merely that of overcoming losses at the head and it doesn't have to tackle the 6dB rise per octave you get on playback. In consequence, its main function is to give treble boost plus, in some instances, a little bass boost as well. The latter is usually down around 100c/s or so. When we're recording we need both an erase signal and a

bias signal, and this is obtained by using the pentode, which previously functioned as the output valve, as the erase oscillator. The output of the erase oscillator goes directly into the erase head, and a bit is coupled over, to provide bias, to the record-playback head, which is now functioning as a recording head. I've also added a few odds and ends which we didn't look at previously. A tape recorder usually has a high level input socket for recording from the radio and similar signal sources, and this socket could conveniently couple in at the anode of the first voltage amplifier. Again, a socket for monitoring may be provided. This can be run from the anode of the last voltage amplifier by way of a resistor of around 100kΩ. There is

sufficient signal amplitude here to operate a pair of headphones, and the series resistor ensures that these do not upset conditions in the recorder circuits themselves. However, you'll find that the input and output sockets provided in domestic tape recorders vary considerably from make to make, and that it's impossible to generalise. The radio input and monitor output sockets I've put in my sketch are, however, fairly typical. You may note, also, that a gain control appears in the amplifier chain. This functions as a volume control on 'playback' and as a recording level control on 'record'."

### Additional Circuits

Smythy drained his mug and once more held it out. Again, Dick picked it up and carried it over to the Workshop sink for replenishment.

"We've covered the essential basics of the domestic valve recorder," said Smythy, as Dick returned. "Have you any questions?"

"Oh yes," said Dick, as he placed Smythy's mug on his bench. "You haven't, for a start, said anything about the recording level indicator."

"There's nothing very complicated in *that* part of the circuit," replied Smythy carelessly. "The usual sort of thing you bump into is a Magic Eye level indicator employing the same principles as the Magic Eye tuning indicators fitted in valve radio receivers which operate off a.g.c. voltage. In tape recorders, the normal approach is to rectify the a.f. at the end of the constant

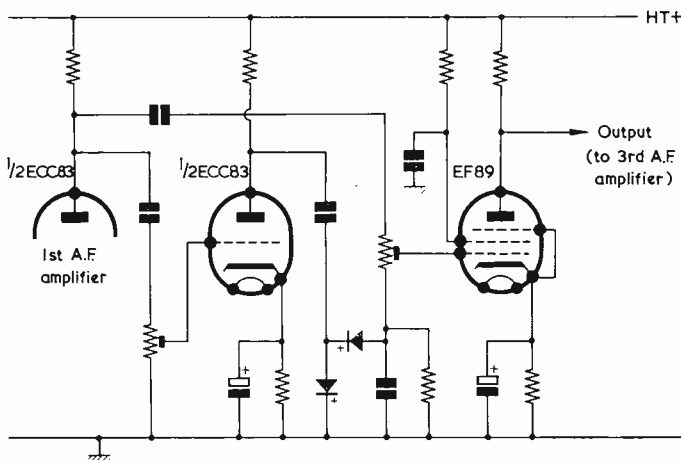

Fig. 9. A simplified diagram illustrating the principle of an automatic recording level circuit. The circuit is shown for 'record'. On 'playback', the EF89 is switched out of circuit and the subsequent a.f. amplifier is fed from the anode of the second ECC83 triode. Automatic recording level control, as shown here, is employed in Elizabethan recorders

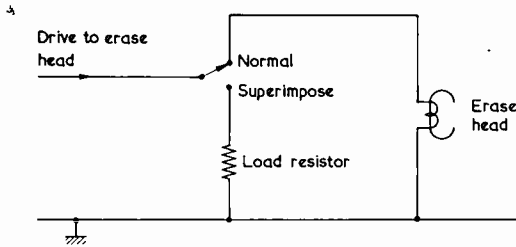

Fig. 10. When 'superimpose' is selected the erase head is switched out, and a load resistor of suitable value is connected in its place

current drive resistor which is remote from the record head. The rectifying diode is connected so that the rectified voltage is negative of chassis and this is then applied, by way of a capacitor and resistor to give a short time constant, to the grid of the Magic Eye. Sometimes, the resistor is made a preset pot to enable you to adjust the level at which the Magic Eye just closes. There's a typical circuit in that manual of yours which gives you the main idea. (Fig. 8). Occasionally, neon bulbs are used. These are coupled into the anode circuit of the voltage amplifier valve driving the record head and they glow when the a.f. reaches a predetermined level."

"Some recorders," offered Dick, "don't have level indicators. Instead, they use a circuit which prevents you overloading when you're recording."

"So they do," confirmed Smithy, picking up his pen and scribbling out a circuit on his pad. (Fig. 9). "And a very neat scheme it is, too. On 'playback' you have the same three triode voltage amplifiers and output pentode that we've been considering up to now. But, when you go on to 'record', the second triode amplifier is whipped out of the amplifying chain and is replaced by an EF89 vari-mu pentode as I've drawn here. The triode which has been taken out of circuit still continues to amplify, though, and its output is applied to two diodes in a voltage-doubling rectifier circuit. These feed a negative grid bias voltage to the EF89, the bias voltage increasing when the signal input increases. In consequence an increase in input signal amplitude causes the EF89 to offer reduced gain, and the result is that the signal at the EF89 anode maintains a reasonably constant level despite wide changes in input signal amplitude."

"That is neat," agreed Dick approvingly. "Now, another thing I'm not too certain about is this 'superimpose' business. How does that work?"

"'Superimpose' is something else which is quite simple," replied Smithy. "All that a 'superimpose' switch does is to disconnect the erase head from the erase oscillator circuit, and connect a load resistor of suitable value in its place (Fig. 10). There is no alteration to the bias signal. The 'superimpose' idea means that you can record without automatic erasure as the tape passes the erase head. In other words, you can put a further recording on top of a recording which has already been made."

"I see," said Dick. "What about 4-track decks?"

"So far as mono recorders are concerned," replied Smithy, "4-track circuits are virtually the same as 2-track circuits, with the exception that you have a switch to change over from one set of heads to the other. (Fig. 11). The general circuitry of the recorder is unchanged, although there may be slight differences in drive and bias level, and so on, as compared with a 2-track machine."

"A further point," Dick pressed on, "is about power supply circuits."

"You've certainly got plenty of questions piled up," commented Smithy. "Anyway, let's keep on at them! So far as power supplies are concerned, practically all domestic tape recorders use the same circuit. This consists of a mains transformer giving complete isolation from the

mains and having an h.t. secondary which feeds into a bridge rectifier. (Fig. 12). There is also a 6.3 volt heater secondary and this is very often provided with a humdinger which is adjusted for minimum hum as specified in the manufacturer's book of words. Incidentally, the fact that a humdinger is fitted emphasises, once more, how susceptible the early stages of a tape recorder amplifier are to hum pick-up. Quite a few recorders even have hum-bucking coils in series with the record-playback head to keep the hum level down. These are positioned so that they pick up a hum which is equal and opposite to that picked up by the head itself. You'll occasionally meet a recorder which doesn't have a humdinger. The chassis connection to the heater circuit is then made via a centre-tap in the heater winding or, even, at one end of it."

#### A Final Question

Smithy drained his mug for the third time that morning.

"And that," he remarked, "really must be the end. Back to your labours, Dick, me handsome!"

"I've only got," wheedled Dick, "one more question."

"Oh, all right, then," said Smithy, "but make it a quick one."

"Can you give me any gen," asked Dick, "about this business of accidental head magnetisation?"

"Oh that," replied Smithy. "Well, the first thing is that, if the heads become magnetised, you're liable to get an increase in background noise. The most important precaution is to keep ferrous objects like screwdrivers, which may be magnetised, away from the head faces. You should, in fact, treat the heads with great respect, and only clean and adjust them in the manner specified by the maker of the recorder."

"Is it true," asked Dick, "that you shouldn't check a head for continuity with a testmeter, in case

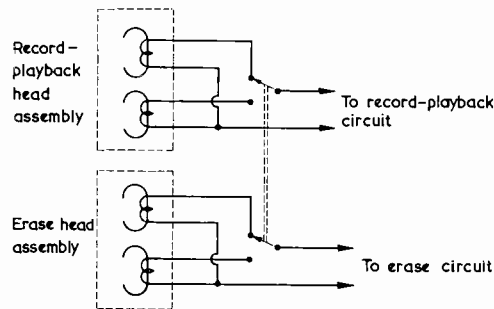

Fig. 11. In a 4-track recorder the two sets of heads may be switched into circuit in the manner shown here

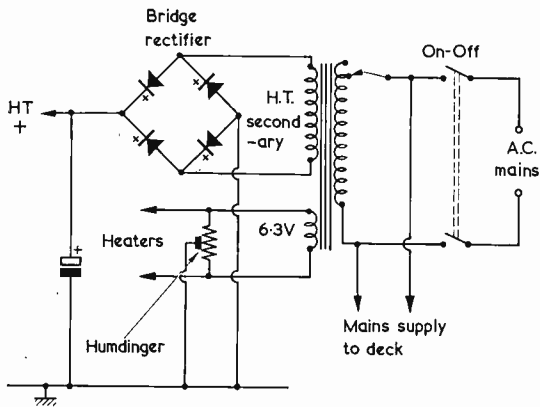

Fig. 12. The power supplies in domestic tape recorders almost always employ a bridge h.t. rectifier. A humdinger across the heater secondary is commonly used

the meter current causes it to be magnetised?"

"Some manufacturers," replied Smithy, "don't pass on any specific instructions these days on that particular subject. At the same time, others state quite definitely that the heads in their instruments should never be tested for continuity with a testmeter. This is one of those things on which I would advise caution. The best thing to do is to play safe and *not* check heads

for continuity. You can soon tell whether a head is open-circuit or not by the general performance of the circuit, and they don't go open all that often in any case. Incidentally, if you happen to have a magnetised erase head and don't have a head demagnetiser to hand, a useful dodge consists of putting the machine to 'record' and switching off the mains supply. This causes the erase current in the head to decay slowly as the h.t. electrolytics dis-

charge, and it may do the trick in some cases. If it's one of your lucky days, this idea may even demagnetise a record-playback head, because of the decaying bias voltage."

"Talking of bias," interjected Dick, "I suppose you suggested lack of bias with that tape recorder I was working on just before tea-break because previous recordings hadn't had the same distortion as when I recorded on it myself."

"That's right," said Smithy. "The bias coupling may have gone wrong since those previous recordings were made. It's only a guess, mind you, but it's one of the things you should look for when you commence work on it again."

"Okeydoke," said Dick, as he rose and walked back to his bench.

"And there's another thing."

"Yes?"

"When you get started on that recorder," said Smithy sweetly, "just keep the volume down a bit, will you? Because if you don't, my old mate, I shall very speedily be applying a bit of bias to *your* head!"

#### Editor's Note

The 'service manual' mentioned in this month's episode of "In Your Workshop" does not, of course, apply to any particular model of recorder. The circuits shown are taken from general tape recorder techniques.

## S.T.C. AT THE 1966 AUDIO FAIR

### Hotel Russell

### 14-17 April 1966

### Room No. 249, 2nd Floor

At the Audio Fair this year Standard Telephones and Cables Limited will be taking a rather different approach in demonstrating the capabilities of the microphones manufactured by their Electro-Mechanical Division at Harlow.

At a carefully controlled studio recording session held a few weeks before the Fair, stereophonic tape recordings were made with top-grade professional equipment using four different types of S.T.C. microphone: the 4113 ribbon, the 4105 moving coil, the 4038 high quality ribbon, and the 4126 capacitor. These microphones cover a price range from £12 to £100. At playback sessions throughout the period of the Fair visitors will be able to judge for themselves the results obtainable with the four different types.

For the recording session a top-flight professional string quartet of London players was assembled—Max Salpeter (1st violin), Leonard Dight (2nd violin), Keith Cummings (Viola), and Douglas Cameron (Cello)—all names that are well-known to London concert-goers.

The playback sessions, which will be held hourly, on the half-hour, from 11.30 a.m. to 7.30 p.m., will last for about 25 minutes, and will use some of the highest quality audio equipment available.

In the lobby adjoining the S.T.C. demonstration room there will be a comprehensive display of microphones, headsets and accessories.

# New Photon Coupled Devices

By J. B. Dance, M.Sc.

ONE OF THE DISADVANTAGES OF MOST ELECTRONIC devices is the lack of isolation between input and output. Although one can sometimes isolate input and output by the use of transformer or capacitive coupling, this cannot be done in amplifiers which must operate at zero frequency. New devices are being developed which employ photons of visible or of infra-red light as the coupling agent.

One device which employs a small tungsten filament or neon lamp to switch a cadmium selenide photoconductive cell has already been described in this journal,<sup>1</sup> but it cannot act as a normal amplifier, since it is merely an on/off device.

## Photoemissive Devices

New high speed devices are being developed in which a gallium arsenide photoemissive diode is used to provide infra-red light which falls on a phototransistor or photodiode. The symbol for the type of device employing a phototransistor is shown in the diagram. The gallium arsenide photoemissive diodes are somewhat similar to the gallium arsenide laser diodes,<sup>2</sup> but operate at much lower levels, need not be cooled and do not emit coherent light. They are placed in a dark enclosure together with the photodiode or phototransistor detector. Although the efficiency of the photoemissive diodes is only of the order of 0.2%, the light output can be made proportional to the signal input, so that a true amplifier instead of an on/off device can be made.

Devices using photodiodes can operate at extremely high speeds, the response time being measured in nanoseconds.\* Although the response time of phototransistors is considerably greater than that of photodiodes, they have the advantage that they provide a very useful gain. The output from the device may be used to operate other electronic equipment or possibly a relay.

It should be noted that the output and input are completely isolated from each other (except for the very small stray coupling capacitance and very high leakage resistance). The voltage between the input and output terminals may be as much as 10,000 volts, although the actual input and output voltages are themselves quite small.

## Applications of GaAs Devices

A particularly useful application of photon

coupled devices involves the modulation of the intensity of a cathode ray tube beam of an oscilloscope. The output side of the photon coupled device is placed in the grid-cathode circuit of the cathode ray tube and is at a high negative potential with respect to earth.<sup>3</sup> The controlling potential is fed to the gallium arsenide photoemissive diode which is at about earth potential.

Some rather interesting types of photon coupled oscillators may be constructed using two of the devices.<sup>3</sup> They have the advantage over conventional multivibrator circuits that a change of load does not affect the performance, e.g. by changing the frequency.

A further application is the regulation of high voltage supplied. One side of the device is at the high potential, whilst the other side is at about earth potential.<sup>3</sup>

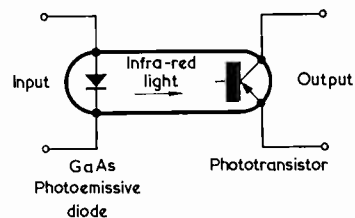

## Betaristors

The betaristor<sup>4</sup> consists of a self-powered light source containing the radioactive isotope tritium (hydrogen-3) in a dark enclosure together with a cadmium sulphide photoconductive cell. It is intended to be used for the control of concentration, level, etc. For example, if the room in which it is placed fills with smoke, this will prevent the light passing from the light source to the photoconductive cell. The output may be used to sound a warning or turn on a fire sprinkler.

Absorption betaristors may be used for the control of the level of opaque liquids. As the liquid is pumped into a tank containing the betaristor, the level will rise until it prevents the light from reaching the photoconductive cell. The output from the cell is used to switch the pumps off. When the level falls, light once again reaches the cell and the pumps are switched on.

Variable mask betaristors may be used for the measurement of small displacements, torque, viscosity, etc.

The main advantage offered by the betaristor is its very high reliability. The isotope used is a relatively non-toxic one, but in any case it cannot escape from the light source which is, therefore, perfectly safe.

## References

1. "The Raylay", *The Radio Constructor*, August 1965, p. 63.
2. J. B. Dance, "Lasers—Part 2. The Types of Laser", *The Radio Constructor*, July 1965, p. 845.
3. Hewlett-Packard Ltd., "Photon Coupled Devices", *Electronic Components* (United Trade Press, Ltd.), May 1965, p. 407.
4. "Diary of Developments", July 1965, p. 14 (published by Nuclear Enterprises Ltd., Sighthill, Edinburgh, 11).

\* A nanosecond is one thousandth of a microsecond.—EDITOR.



# TRANSISTORISED A.C. MILLIVOLTMETER

Part 1

by H. Smith and D. L. Woolley, B.Sc.

This article is the first of a 2-part series which gives full constructional details of an easily-built a.c. millivoltmeter having a range from 10mV to 100V full-scale deflection, together with a flat response up to 200 kc/s on the volt ranges and up to 400 kc/s on the millivolt ranges. The meter is unaffected by external fields and has a very high input impedance

THE MILLIVOLTMETER DESCRIBED IN this and next month's issue has 9 ranges from 10 millivolts to 100 volts full-scale, and it can also be used to measure decibels, having an overall range from -46dB to 40dB, 1 volt representing 0dB. The frequency response of the millivoltmeter is flat between 20 c/s and 200 kc/s, and an extended high frequency response up to 400 kc/s is obtained on the millivolt ranges. The frequency responses for volt and millivolt ranges are shown in Fig. 1.

In order not to present an appreciable load to any circuit under test, the input impedance has been made as high as possible. Although the impedance varies slightly with frequency, it is not less than 680 k $\Omega$  on the 3 to 100 volt ranges. The 1 volt range, together with the millivolt ranges, uses a pre-amplifier

having a high input impedance of the order of 1 M $\Omega$ .

Most of the millivoltmeter components are mounted on a printed circuit board, designed so that it may easily be reproduced; the remaining larger components are mounted, together with the printed circuit board, within a metal case built in units made from sheet aluminium and brass angle section. As the millivoltmeter is battery driven and as its components are fully screened by the metal case, there is no deflection on the meter due to mains hum on any range. Noise produced by the amplifier is very low and produces no deflection on any range.

A calibration control is provided on the front panel of the instrument so that all the ranges may be calibrated easily. This process is described fully in next month's issue.

## Circuit Description

The circuit of the millivoltmeter is shown in Fig. 2. To the right of the dotted line are the attenuator networks and the main amplifier. The alternating voltage (the signal) to be measured is fed into the base of TR<sub>3</sub> via isolating capacitor C<sub>2</sub> (to bar direct current from the millivoltmeter) and a potential divider formed by R<sub>17</sub>, the base input impedance of TR<sub>3</sub> and the appropriate resistor, R<sub>8</sub> to R<sub>11</sub>, switched in by S1.<sup>1</sup>

TR<sub>3</sub> amplifies the signal, which is then directly coupled to the base of TR<sub>4</sub>. After further amplification the signal is fed via C<sub>6</sub> into a full wave bridge rectifier, formed by crystal diodes D<sub>1</sub> to D<sub>4</sub>, which produces a direct current to operate the meter, M<sub>2</sub>. Finally the signal is fed back to the emitter of TR<sub>3</sub> where, as will be described shortly, it controls the overall gain of the amplifier. TR<sub>3</sub>, TR<sub>4</sub> and their associated components form a direct coupled amplifier which has good temperature stability, since each transistor has direct control over the base bias conditions of the other. (For example, if the collector-emitter leakage current of TR<sub>3</sub> increases as a result of a rise in temperature of this transistor, the collector current increases, the voltage drop across R<sub>18</sub> increases and the base bias voltage on TR<sub>4</sub>

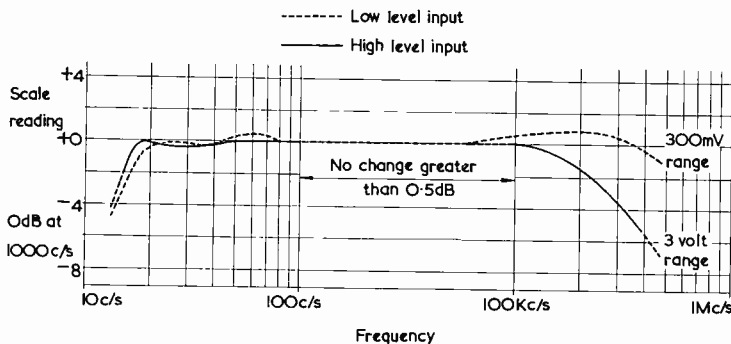

Fig. 1. The measured frequency response of the millivoltmeter

<sup>1</sup> Ideally, R<sub>19</sub> is in parallel with R<sub>17</sub>, assuming C<sub>7</sub> to have negligible impedance compared with R<sub>19</sub>, and so forms part of the attenuator.

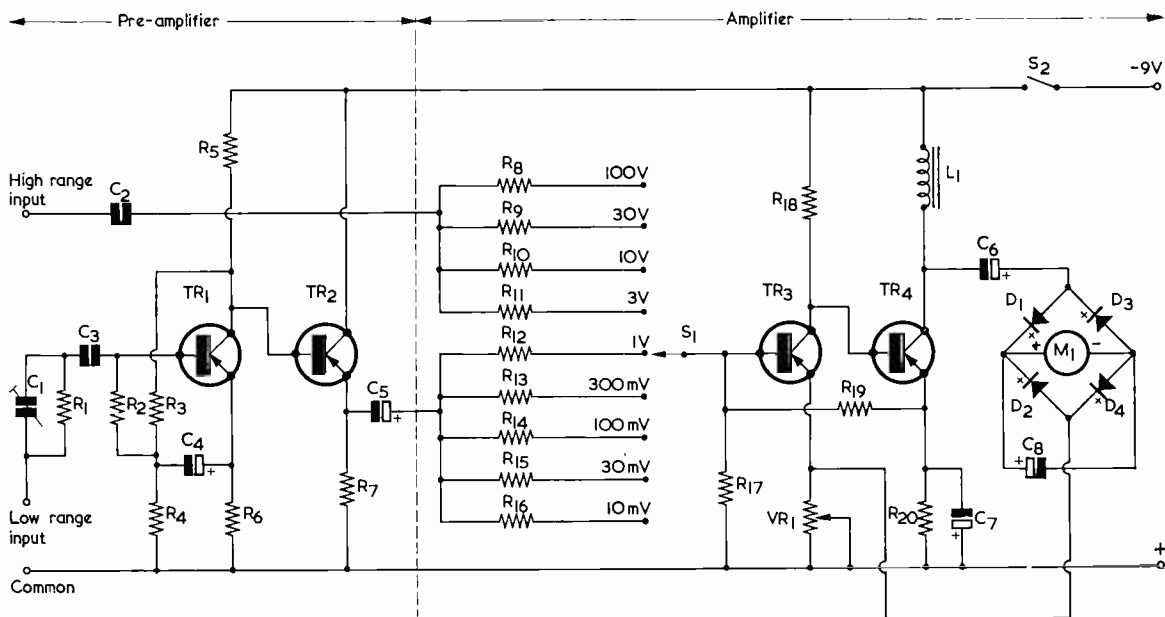

Fig. 2. The millivoltmeter circuit diagram. If desired, S<sub>2</sub> may be combined in a 3-way switch which enables the battery voltage to be checked, and this point is discussed in the second article in this series

**General Note.**

It should be noted that some of the components listed here are discussed at length in the second part of this article, and that the reader should not attempt to obtain them before reading this second part. The components concerned are the range resistors R<sub>8</sub> to R<sub>16</sub>, R<sub>21</sub>, the switches, the aluminium panels and the meter.

**Resistors**

(All fixed values 1/2 watt 5% high stability. See text)

- R<sub>1</sub> 1MΩ
- R<sub>2</sub> 47 kΩ
- R<sub>3</sub> 47 kΩ
- R<sub>4</sub> 10 kΩ
- R<sub>5</sub> 22 kΩ
- R<sub>6</sub> 2.2 kΩ
- R<sub>7</sub> 2.7 kΩ
- R<sub>8</sub> 22 MΩ
- R<sub>9</sub> 6.8 MΩ
- R<sub>10</sub> 2.2 MΩ
- R<sub>11</sub> 680 kΩ
- R<sub>12</sub> 220 kΩ
- R<sub>13</sub> 68 kΩ
- R<sub>14</sub> 20 kΩ
- R<sub>15</sub> 3.3 kΩ
- R<sub>16</sub> 1 kΩ
- R<sub>17</sub> 4.7 kΩ
- R<sub>18</sub> 5.6 kΩ
- R<sub>19</sub> 22 kΩ
- R<sub>20</sub> 150 Ω
- R<sub>21</sub> Battery check meter resistor
- VR<sub>1</sub> 50Ω potentiometer, wire-wound

} Range resistors

**Components List**

**Capacitors**

(see text)

- C<sub>1</sub> 50pF air-spaced trimmer
- C<sub>2</sub> 0.47μF 400V wkg.
- C<sub>3</sub> 0.47μF 400V wkg.
- C<sub>4</sub> 50μF electrolytic 15V wkg.
- C<sub>5</sub> 50μF electrolytic 15V wkg.
- C<sub>6</sub> 8μF electrolytic 15V wkg.
- C<sub>7</sub> 100μF electrolytic 15V wkg.
- C<sub>8</sub> 1,000μF electrolytic 15V wkg.

**Inductor**

- L<sub>1</sub> Choke. 10 henry, 50mA. D.C. resistance less than 500 Ω.

**Semiconductors**

- TR<sub>1</sub> OC44
- TR<sub>2</sub> OC45
- TR<sub>3</sub> OC42
- TR<sub>4</sub> OC76
- D<sub>1, 2, 3, 4</sub> OA81

**Switches**

- S<sub>1</sub> 1-pole 11-way, wafer switch, ceramic insulation
- S<sub>2</sub> s.p.s.t. switch
- S<sub>3</sub> (alternative to S<sub>2</sub>) 3-pole 3-way wafer switch

**Meter**

- M<sub>1</sub> Moving coil meter. F.S.D. 500μA, d.c. resistance 100Ω

**Battery**

9-volt battery type PP9 (Ever Ready)

**Miscellaneous**

- 3 knobs
- 3 input terminals. Type L1001/1W (Belling-Lee) or similar
- Printed circuit board and etching materials
- Battery clips
- Aluminium panels (Obtainable cut and bent to size from H. L. Smith & Co. Ltd.)

becomes more positive, or less negative. Such a change causes a decrease in the collector current of TR<sub>4</sub>, hence a decrease in voltage drop across R<sub>20</sub>. This decrease in voltage is passed by the potential divider R<sub>19</sub> and R<sub>17</sub> to the base of TR<sub>3</sub> which becomes more positive, thus reducing the collector of TR<sub>3</sub> and so counteracting the original current increase).

Unfortunately, the gain of each transistor will increase with temperature rise and, although the no-signal conditions of the amplifier will remain stabilised, the overall gain of the amplifier will vary with temperature. However, the signal fed back from the bridge network is out of phase with the incoming signal component at the emitter of TR<sub>3</sub> and so can be considered as

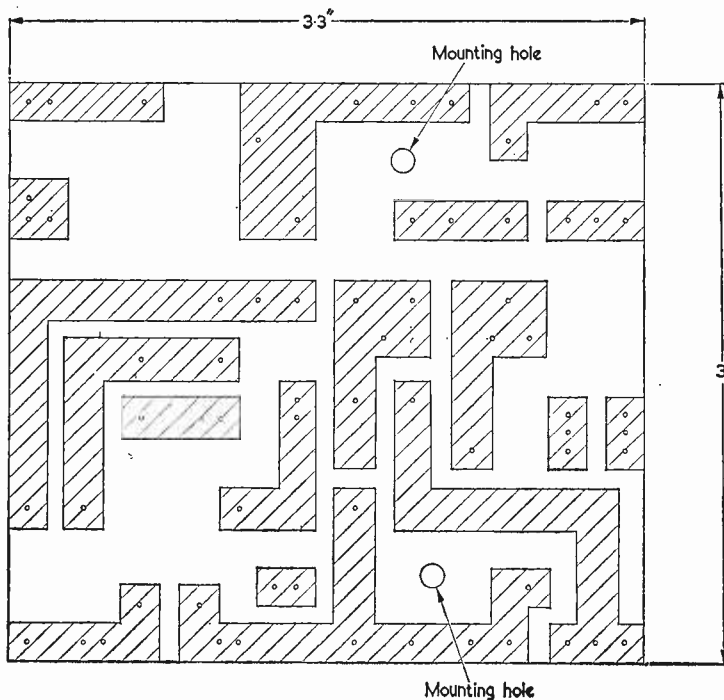

Fig. 3. The conductor side of the board. This is reproduced full size and may be traced. Copper sections are shown shaded

negative feedback. In fact, the feedback loop can reduce the amplifier gain by a factor of 10 times. Thus any change in gain of the amplifier with temperature or frequency change is automatically controlled, as is any non-linearity of the bridge circuit. By adjusting VR<sub>1</sub>, (the calibration control) the amount of negative feedback can be varied and thus the overall gain of the millivoltmeter can be controlled.

Although a resistor could have been used instead of L<sub>1</sub> as the load for TR<sub>4</sub>, the fact that this transistor consumes about 7mA makes the maximum value for such a resistor, to avoid cut-off in TR<sub>4</sub>, about 1 kΩ. Such a value would have reduced the gain of the amplifier considerably. The impedance of the choke is high, even at low frequencies and thus the gain of the amplifier is high also.

The moving coil meter, M<sub>1</sub>, has an f.s.d. of 0.5mA and an internal resistance of 100Ω. However, because of the feedback loop it is possible to use any convenient meter with an f.s.d. between 200 μA and 1mA, and any value of internal resistance between about 1 kΩ and 50Ω. The more sensitive the meter, the greater will be the

amount of feedback required and the better will be the frequency response of the millivoltmeter. If a very sensitive meter is used, the range resistors R<sub>8</sub> to R<sub>16</sub> will have to be increased in value, for the calibration control may then not have enough range.

Capacitor C<sub>8</sub> damps the meter movement considerably and enables voltages at very low frequency to be measured. Also, C<sub>8</sub> controls the sudden kick of the meter pointer caused by current surges on switching the millivoltmeter on and off.

To the left of the dotted line is the pre-amplifier. On the millivolt ranges, the signal is fed, via C<sub>1</sub>, R<sub>1</sub> and isolating capacitor C<sub>3</sub> to the base of TR<sub>1</sub>. C<sub>1</sub> is used to increase the high frequency response of the circuit, and it bypasses R<sub>1</sub> to an increasing extent at the high frequencies. TR<sub>1</sub> acts as a voltage amplifier, its base bias circuit, consisting of R<sub>2</sub>, R<sub>3</sub> and R<sub>4</sub>, increasing the input impedance at the base.

TR<sub>2</sub> and R<sub>7</sub> form an emitter follower circuit having a high input impedance (presenting a negligible load to TR<sub>1</sub>) and a very low output impedance that is unaffected by the switching in of range resistors R<sub>12</sub>

to R<sub>16</sub>. The overall gain of the pre-amplifier is near unity, its main purpose being to increase the input impedance on the millivolt ranges. Experiments have shown that temperature changes have very little effect on the pre-amplifier. In a series of tests, the gain was found to vary by approximately 1% for a temperature rise of 10°C.

It will be noted that the conventional large value bypass capacitor which might normally be expected to be connected across the supply lines is not included in the present design. Such a capacitor is usually required because, as the battery ages and nears the end of its useful life, its internal resistance increases. The battery may then cause unwanted common coupling at audio frequencies between different parts of the circuit, giving rise to unstable amplification. To keep the impedance of the supply circuit as low as possible at all frequencies it is common practice to bypass the battery with a large electrolytic capacitor of say 100μF or more. The effect of such a capacitor was tried with the present design, using an old battery with a series resistor to accentuate any internal resistance effects. None were noticeable, and so a bypass capacitor was not employed.

If, nevertheless, it is desired to use a bypass capacitor, one of 100μF at 15 volts working should be wired across the positive and negative battery leads on the printed board.

#### Preparation of the Printed Board

The first stage in the preparation of the printed board is to cut a piece of copper laminated board to the correct size; i.e. 3 by 3.3ins. Probably the best tool to use for cutting the board is an Eclipse Junior hacksaw, as the saw teeth are fine and do not tend to chip the brittle laminate. All saw cuts should be made from the copper side of the board as there is then no tendency for the saw teeth to break the bond between the insulating and copper laminates. An ordinary steel woodworking block-plane, set very fine and well sharpened, can be used to plane the sawn edges of the board in order to produce straight edges and right-angled corners, the board being held edge upwards in a woodworking vice.

The board should now be cleaned with fine steel wool and placed in Ferric Chloride etching solution for about 10 to 20 seconds, but no longer. After washing the board and drying it with a soft cloth, the copper surface will now be a dull, salmon-purple colour. This surface will



take pencil marks easily, whereas the original shiny surface is very difficult to mark. With the aid of a sharp HB pencil and a small ruler marked in tenths of an inch, the printed circuit design may now be copied from Fig. 3 (which is reproduced to scale) directly on to the board. Only the outlines of the copper strips to be left unetched need be drawn.

A resist has now to be applied to the copper surface in order to protect the actual circuit from the etching solution. Any oil-based or cellulose-based paint will act as a resist but Brushing Belco is recommended as it dries fairly rapidly and has been used by the authors very successfully on many occasions. The paint, in any chosen colour, should now be painted over all the copper areas that are to remain unetched, using a No. 2 or similar fine water colour brush. Care must be taken to apply a fairly thick, hole-free layer, avoiding the areas of copper to be etched.

If painting has been concluded satisfactorily it is possible to etch the board almost immediately, as the paint recommended need not dry fully before it resists the action of the etching solution. However, for those who find it difficult to paint a good straight edge, the best policy is to leave the paint to dry hard overnight and touch-up the design with a sharp pen-knife and ruler. The uneven edges and rounded corners may be cut straight and the surplus paint easily removed.

The etching solution has already been mentioned. It is prepared by dissolving Ferric Chloride crystals in water, a suitable ratio being:—

250gm. of Ferric Chloride to 500cc. of water; i.e. about 8oz. of Ferric Chloride to 1 pint of water.

This ratio produces a strong solution which dissolves copper rapidly. Weaker solutions do the job equally well, but take a longer time. At normal room temperature the strong solution will take only 10 to 15 minutes to etch through the copper normally used on laminated boards. The solution may be used over and over again, but it takes a longer time to etch through the copper as it becomes more exhausted. If the board is actually floated on the surface of the Ferric Chloride solution, copper side downwards, the etching process is completed speedily. Care must be taken to avoid air bubbles, which adhere to the surface and prevent etching.

When all the unprotected copper has been dissolved, the board should be removed from the etching solu-

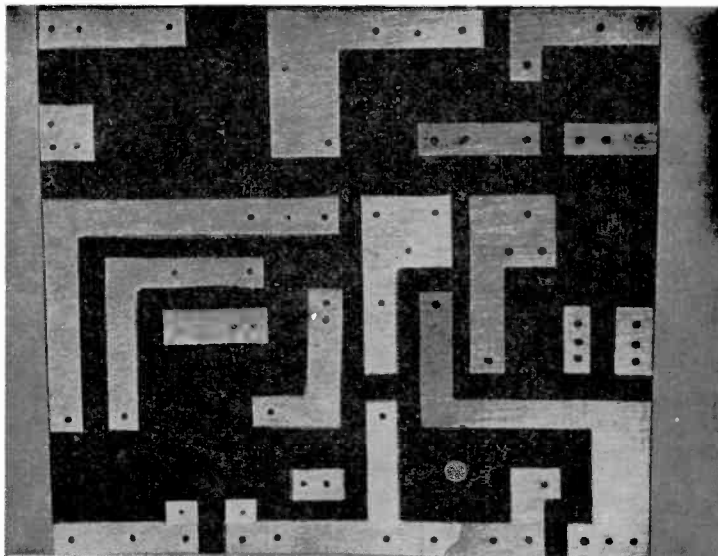

*The copper side of the printed circuit board after etching*

tion, washed in tap water and dried. Although the paint could now be removed, it is better to leave it in situ as a protection for the copper whilst the holes are drilled in the board. A No. 55 twist-drill or one of similar size is used to drill all the mounting holes, drilling being carried out with a hand drill or mounted power drill. A piece of wood should be used to back-up the laminate to prevent chipping as the drill breaks through the board. All drilling should start from the copper side of the board. The two mounting holes in the board should

be drilled with a No. 30 or  $\frac{1}{16}$  in drill.

The paint should now be removed with acetone or cellulose thinners and the board cleaned carefully with fine steel wool.

#### Mounting Components on the Printed Board

As the millivoltmeter is a piece of test equipment, it is desirable that its components have good stability so that the overall characteristics of the instrument vary as little as possible with time. Therefore, every component used in the prototype instrument was bought

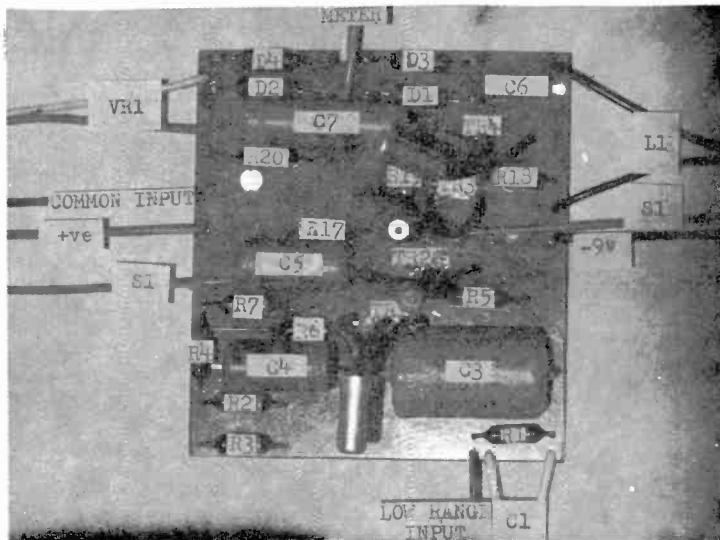

*The components mounted in position on the board*

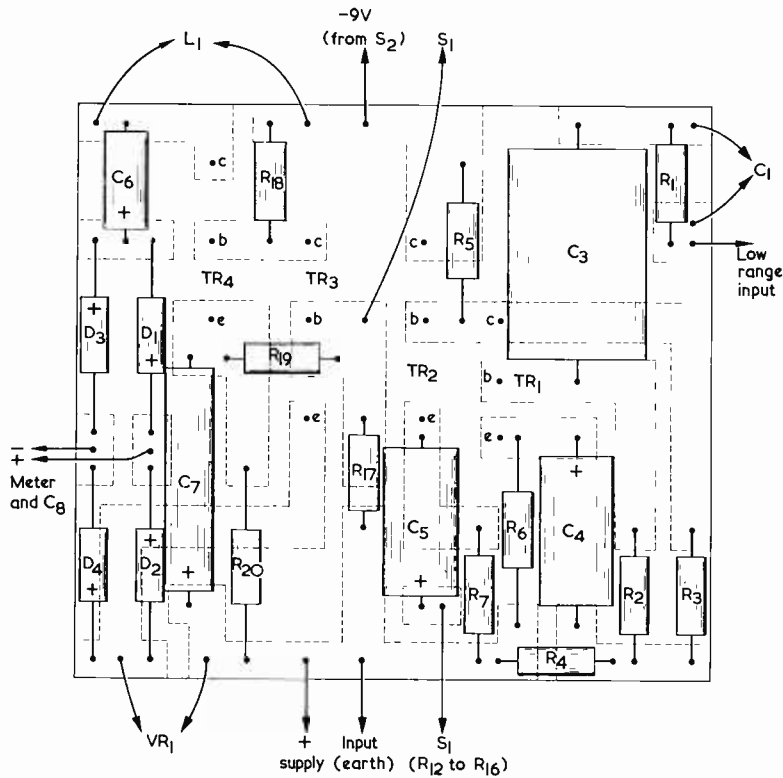

Fig. 4. The component side of the board with components mounted. Also shown are lead-out wires from the circuit external to the boards

new, and tested before being mounted on the printed board or within the metal case. All resistors are of the  $\frac{1}{2}$  watt, 5% tolerance high stability type available from Radiospares Ltd. The electrolytic capacitors are also Radiospares types, but the non-electrolytic capacitors are Mullard polyester components.<sup>7</sup> Each of the four Mullard transistors was tested for emitter-collector leak-

age and current gain before being soldered into the circuit.

Work may commence with the printed board, and the resistors should be soldered in place first of all. Before each one is fitted into position, its leads should be lightly scraped in order to make sure that they are clean, and then bent carefully to the correct shape to fit the relevant holes on the board. When bending the leads, they should not be bent sharply near to the body of the resistor as the protective coat on the resistor may be damaged. On the copper side of the board the leads should be about  $\frac{1}{16}$  in long and bent over flat against the copper. The printed board component layout is shown in Fig. 4.

Capacitors, lead-out wires to the circuit external to the board, diodes and transistors should next be mounted on the printed board, in that order. Care must be taken to connect electrolytic capacitors the correct way round. There are fourteen lead-out wires and, since many of these will be twisted together later on, it is a good policy to adopt a colour code of some kind. If single stranded p.v.c. insulated wire is used it may be obtained in many different colours and it also keeps its position when twisted together. Each lead-out wire should be cut to an initial length of about 12ins, as it is very easy, during the final wiring, to cut the leads to the correct length.

The diodes are sensitive to heat and if loops are made in their leads as shown in Fig. 5, the heat given by the soldering process will have a long route to travel before it reaches the diode envelope. There is no reason to shorten the transistor leads which should, therefore, be left full length. They should be insulated with p.v.c. insulation taken

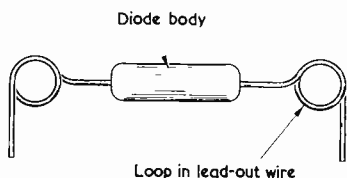

Fig. 5. The diode lead-out wires may be formed in a loop to increase the distance between the solder joint and the diode body

from the lead-out wires. Provided that an excessively long time is not taken to solder each transistor

lead, there should be no need to use a heat-shunt. If the soldering iron is at the correct temperature

and cored solder is employed, it should be possible to make a really sound joint in less than five seconds.  
(To be concluded)

IN THE LAST ARTICLE IN THIS SERIES WE CONCLUDED our discussion on the triode as voltage amplifier and examined some practical triodes, as are encountered in commercially manufactured radio and audio amplifying equipment.

We now turn our attention to a further factor which has to be considered in relation to the triode, this being Miller Effect, after which we shall introduce the subject of the triode as oscillator.

cathode). More complicated expressions for inter-electrode capacitances may also be encountered, two typical examples being  $c_{g-h+k}$  and  $c_{g-all}$ . The first of these expressions refers to the capacitance given with the grid as one "plate" of the effective capacitor, and the heater and cathode joined together as the other. The second (which is usually applied to valves having more complicated electrode structures than the triode) refers to the capacitance

# understanding

## Miller Effect, and the Triode Oscillator

By W. G. Morley

### Inter-Electrode Capacitance

Since the electrodes of a triode valve are in fairly close proximity to each other, it follows that a capacitance exists between them. Capacitances also exist between the leads and pins connecting to the electrodes, these capacitances being in parallel with the capacitances existing between the associated electrodes themselves.

In conventional voltage amplifier triodes the inter-electrode capacitances are quite small and are normally less than some 2.5 pF. These small capacitances have negligible effect on circuit operation in some applications, but in others they are of importance and have to be taken into account. Inter-electrode capacitances are identified by the small letter "c" followed by suffix letters designating the electrodes concerned.<sup>1</sup> Thus, the expression  $c_{a-g}$  represents the capacitance between anode and grid,  $c_{g-k}$  the capacitance between grid and cathode and  $c_{a-k}$  the capacitance between anode and cathode. Also of importance is  $c_{k-h}$ , which represents the capacitance between cathode and heater. With directly heated triodes, inter-electrode capacitances to the filament are referred to as  $c_{g-f}$  and  $c_{a-f}$ , the letter "f" (for filament) replacing the letter "k" (for

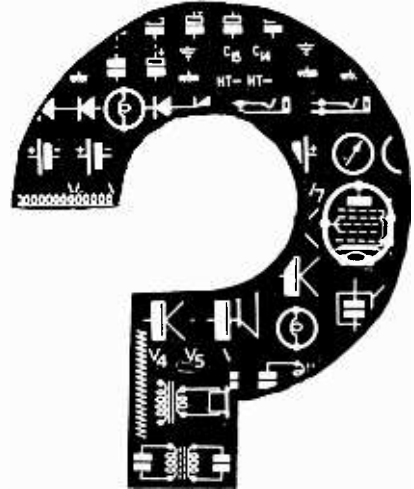

# radio



between the grid as one "plate" and all the remaining electrodes joined together as the other. Modern practice has introduced two further expressions, these being  $c_{in}$  and  $c_{out}$ . The expression  $c_{in}$  stands for the capacitance between the input electrode (the grid) and all other electrodes except the output electrode (the anode) joined together. The expression  $c_{out}$  refers to the capacitance between the output electrode (the anode) and all other electrodes except the input electrode (the grid) joined together.

The expressions for inter-electrode capacitance just given will be found in the specifications for their products which are issued by the valve manufacturers. It may be noted, in passing, that the capacitance figures quoted by manufacturers normally apply, unless otherwise stated, to the valve when it is cold (i.e. no heater or filament supply applied).

<sup>1</sup> The small "c", instead of a capital letter, is used because the capacitance is *inside* the valve. See the footnote on page 325 of the December 1965 issue.

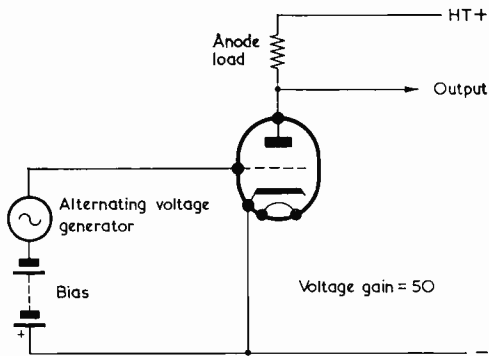

Fig. 337. Illustrating Miller Effect in a voltage amplifier triode. The input capacitance here is  $(50+1) c_{a-g} + c_{g-k}$

To give an idea of the inter-electrode capacitances offered by practical valves the  $c_{in}$  of either triode of the double-triode ECC82 is specified<sup>2</sup> as 1.8pF and the  $c_{a-g}$  as 1.5pF. The  $c_{out}$  of one of the triodes is specified as 0.370pF and the  $c_{out}$  of the other triode as 0.250pF.

### Miller Effect

When a triode is employed as a voltage amplifier an internal action takes place within the valve which modifies the effective capacitance between the grid and the anode, and this action we shall next consider. In Fig. 337 we have a triode voltage amplifier to whose grid is connected a generator. The valve is biased in normal fashion by means of a battery which is assumed to have zero internal impedance, and we shall state, for simplicity in the explanation, that the triode offers a voltage gain of 50.

The function of the generator is to apply an alternating voltage to the grid. Assuming that there is no grid current and that all insulation is perfect, we could then, at first inspection, make the assumption that the generator has to provide no current at all. But such an assumption is not, in practice, true, because the alternating voltage generator is connected to a component having capacitance. Part of this capacitance is given by  $c_{g-k}$ , the capacitance between grid and cathode, and current is required from the generator to ensure that the  $c_{g-k}$  charges and discharges in sympathy with the applied alternating voltage. The  $c_{g-k}$  can be looked upon as a physical capacitor, the upper "plate" being the grid and the lower "plate" the cathode. Obviously, the upper "plate" connects directly to one terminal of the generator, whilst the lower "plate" connects directly (via the bias battery which is assumed to have zero internal impedance) to the other terminal of the generator.

Things are not so straightforward when we come to consider the next inter-electrode capacitance, that between anode and grid. Again, we can think in terms of a physical capacitor, with the grid being

the lower "plate" and the anode being the upper "plate". In this case, however, whilst the lower "plate" of the  $c_{a-g}$  connects directly to one terminal of the generator, the upper "plate" is in a circuit which causes it to have a constantly changing potential.

Let us now examine what happens during a cycle when the alternating voltage generator is causing the grid to go positive. The valve has a voltage gain of 50, and the signal at the anode is 180° out of phase with that at the grid. So, for every volt that the grid goes positive, the anode goes negative by 50 volts. Had the anode voltage remained constant the current in the anode-grid circuit would have been that needed to charge and discharge the  $c_{a-g}$  on its own; but what happens now is that, when we make the lower "plate" of the  $c_{a-g}$  positive by 1 volt the upper "plate" counteracts this by going negative by 50 volts. If we make the lower "plate" negative by 1 volt the upper "plate" counteracts this by going positive by 50 volts. The generator has, therefore, to provide charge and discharge currents which will overcome this 50-fold counteracting effect, and the circuit functions as though we were trying to charge and discharge a capacitor having 50 times the actual value of the  $c_{a-g}$ . This is, indeed, the case, because a measure of capacitance in a capacitor is given by the current which flows when an alternating voltage is applied to it. So far as the generator is concerned, the result is the same as would be given if it applied its output to a capacitor having 50 times the value of the actual  $c_{a-g}$ .

We have, in the last paragraph, considered the apparent capacitance which is 50 times the  $C_{a-g}$ , but we must not forget the physical capacitance given by the  $c_{a-g}$  itself. We have found that the generator has to provide charge and discharge currents to overcome the 50-fold counteracting voltage at the anode, but we must also remember that the generator has to provide the charge and discharge currents which are needed to change the grid potential in the first place. These charge and discharge currents are those resulting from the  $c_{a-g}$  itself. So the overall capacitance, apparent and real, becomes 50 times the  $C_{a-g}$  plus the  $c_{a-g}$  itself, or  $(50+1)$  times the  $c_{a-g}$ .

Another way of looking at the effect just described is to assume initially that the alternating voltage generator is providing zero output, and that the anode swings negative and positive by, say, 50 volts peak. It is obvious that charge and discharge currents due to the  $C_{a-g}$  will flow in the generator. We next cause the generator to provide the output of 1 volt peak which corresponds to the 50 volts at the anode, whereupon the charge and discharge currents are increased by those needed to swing the grid through its 1 volt peak signal. The total charge and discharge currents are then  $(50+1)$  times the currents which would flow due to the  $c_{a-g}$  alone (or which would flow if the anode potential was fixed instead of varying).

Had the voltage gain of the valve in Fig. 337 been 25, the effective anode-grid capacitance, apparent plus real, would have been  $(25+1)$  times

<sup>2</sup> In Mullard literature.

the  $C_{a-g}$ . Had the gain been 40, the effective anode-grid capacitance would have been  $(40+1)$  times the  $c_{a-g}$ . It follows that, if we call the voltage gain  $A$ , the effective anode-grid capacitance becomes  $(A+1)$  times  $c_{a-g}$ .

We can now see that the total capacitance for which the generator of Fig. 337 has to provide charge and discharge currents is  $(A+1)$  times the  $c_{a-g}$ , to which must be added the  $c_{g-k}$  and any further capacitances which exist between the grid and other electrodes which are at h.t. negative potential so far as a.c. is concerned. With a triode the latter may usually be ignored whereupon, for most purposes, it becomes adequate to assume that the capacitance for which the generator has to provide charge and discharge currents is  $(A+1) c_{a-g} + c_{g-k}$ . This capacitance is referred to as the *input capacitance* of the valve under the working conditions applicable. This term should not be confused with the  $C_{in}$  symbol mentioned earlier. The  $C_{in}$  figure is a valve specification and is the result of a capacitance measurement taken when the appropriate valve is *not* operating.

The effect just described, in which the  $c_{a-g}$  is apparently multiplied by  $(A+1)$  is referred to as *Miller Effect*.

Miller Effect can result in relatively high input capacitances for voltage amplifier triodes. The gain of 50 chosen for our explanation is not unusually high by practical standards and is, indeed, the figure we found last month when we examined one triode of the ECC83 in a voltage amplifier circuit employing an h.t. voltage of 250 and an anode load resistor of 100k $\Omega$ . The  $c_{a-g}$  of either triode of an ECC83 is quoted, in the valve manufacturers' literature, as 1.6pF. With a gain of 50, the input capacitance due to Miller Effect then becomes  $(50+1)$  times 1.6pF or 81.6pF. This corresponds to a reactance of approximately 200k $\Omega$  at 10 c/s. If the ECC83 triode under consideration were employed in an a.f. circuit with conventional resistance-capacitance coupling to the grid, this input reactance could result in a loss in overall circuit gain at the higher audio frequencies. Such a loss would be permissible in, say, a low-cost radio receiver, but it would have to be taken into account in the design of an amplifier intended for high fidelity reproduction.

### The Triode as Oscillator

When, earlier, we examined tuned circuits<sup>3</sup> we saw that these became resonant when the capacitive reactance is equal to the inductive reactance. Resonant frequency is then equal to  $\frac{1}{2\pi\sqrt{LC}}$ , where frequency is in c/s,  $L$  is inductance in henrys and  $C$  is capacitance in farads.<sup>4</sup> The series tuned circuit is shown in Fig. 338 (a) and this offers minimum impedance at the resonant frequency. The parallel tuned circuit is shown in

Fig. 338 (b) and this offers maximum impedance at the resonant frequency.

On the earlier occasion we did not look closely into the interchange of energy which takes place in the tuned circuit itself, and this we shall next proceed to do. The manner in which the interchange of energy occurs is quite simple, and it is pertinent to the operation of a triode oscillator. It will be convenient, here, to think in terms of a parallel tuned circuit.

In Fig. 339 we have a capacitor, an inductor and a switch in series. Whilst the switch is open we apply a source of e.m.f. to the capacitor, causing it to become charged. We then remove the source of e.m.f. and close the switch, whereupon the circuit becomes that for a parallel tuned circuit. At the instant of closing the switch, the capacitor commences to discharge into the inductor, causing a continually increasing current to flow in its windings. The inductor opposes the change of current, with the result that a period of time elapses before the capacitor becomes completely discharged and has zero voltage across its plates. At this instant all the energy held by the capacitor now appears in the form of a magnetic field about the inductor. Also, maximum current flows in the circuit.

The magnetic field about the inductor next commences to collapse, inducing a voltage at the terminals of the inductor of opposite polarity to that which occurred when the field was being built up. This voltage causes the capacitor to charge with opposite polarity to that given previously, and the process continues until the field about the inductor is zero and the capacitor is fully charged, with maximum voltage across its plates. The voltage across the capacitor is of reversed polarity to that which occurred initially, and at this instant there is zero current in the circuit. The energy held by the inductor in the form of a magnetic field has now been returned to the capacitor in the form of a charge.

The capacitor next commences to discharge into the inductor once more, and the second half of the cycle commences. After a period, the capacitor becomes completely discharged and a magnetic field of maximum strength appears about the inductor. This field commences to collapse again, causing a voltage of opposite polarity to appear

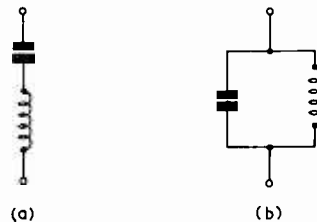

Fig. 338 (a). The series tuned circuit. This offers minimum impedance at the resonant frequency  
(b). The parallel tuned circuit, which offers maximum impedance at the resonant frequency

<sup>3</sup> In the issues of January 1963 to April 1963 inclusive.

<sup>4</sup> In the case of parallel tuned circuits this assumes negligible resistance in the tuned circuit.

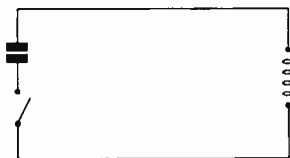

Fig. 339. Demonstrating the interchange of energy which occurs in a tuned circuit. The capacitor is initially charged and the switch is closed. An interchange of energy from the capacitor to the inductor and back again then takes place at the natural resonant frequency of the tuned circuit

across the plates of the capacitor. The cycle is completed when the capacitor is fully charged again (with, now, the same polarity as occurred at the beginning) and there is no magnetic field about the inductor.

If there were no resistance or losses in either the capacitor or inductor this process would continue indefinitely, and if we were to examine the changing voltage across either component we would find that we have the sine wave shown in Fig. 340 (a). This is described as an *oscillation* and is similar in form to the mechanical oscillation which occurs if, for example, a weight on the end of a spring is caused to move up and down by initially extending the length of the spring. The frequency of the oscillation is known as the "natural resonant frequency" of the tuned circuit. For practical radio work the "natural resonant frequency"

may be assumed to be equal to  $\frac{1}{2\pi\sqrt{LC}}$ , this being the expression we have already referred to as defining the resonant frequency where a series tuned circuit offers minimum impedance and a parallel tuned circuit offers maximum impedance.<sup>5</sup>

The sine wave oscillation shown in Fig. 340 (a) represents the voltage across the capacitor or inductor and, as we have stated, its frequency is

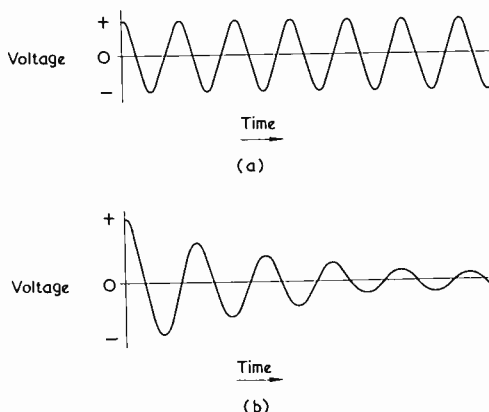

Fig. 340 (a). Assuming zero resistance in the circuit of Fig. 339, the oscillatory voltage given is a sine wave of constant amplitude, as shown here

(b). In practice, resistance must inevitably be present in the circuit, and a damped oscillation results

virtually the same as the resonant frequency of these two components. Assuming no resistance or losses in the tuned circuit, the interchange of energy between capacitor and inductor continues indefinitely, and the amplitude of the sine wave remains constant, as it does in Fig. 340 (a). But we know that such a state of affairs is impossible and that some resistance and losses must inevitably be present. In practice, therefore, there is a loss of energy on each transition of energy from one tuned circuit component to the other, with the result that the voltage waveform produced takes up a form similar to that illustrated in Fig. 340 (b). In this diagram the initial amplitude, as the capacitor first discharges into the inductor, is high, but the amplitude gradually decreases with time as energy is lost on each successive cycle. The waveform of Fig. 340 (b) is described as a *damped oscillation*.

It is evident that, if we want to obtain a continual sustained oscillation, we have to supply energy to the tuned circuit from an outside source to make up for the energy which is lost in its own resistance and losses. A very convenient method of doing this consists of employing a triode amplifier in a circuit such as that illustrated in Fig. 341 (a). In Fig. 341 (a) a parallel tuned circuit is connected between the h.t. negative line and the grid of the valve. Some method of biasing is required and this is provided by means of a grid leak and capacitor. The anode of the triode connects to a coil which is coupled inductively to the coil in the tuned circuit.

When the circuit is oscillating, the sine wave voltage appearing across the tuned circuit is applied to the grid of the triode, whereupon an amplified version appears at the anode. This amplified version is coupled back to the tuned circuit by the anode coil, and it has the same phase as the oscillatory voltage across the tuned circuit. In consequence, it augments that voltage and overcomes the effect of resistance and losses, allowing a sustained oscillation to be produced. The frequency of oscillation is controlled by the inductor and capacitor in the tuned circuit; varying the value of either of these will cause the oscillatory frequency to be altered accordingly.

It is necessary for the connections to the anode coil to be made such that the anode signal fed back to the grid is in phase. If we reverse the connections to the anode coil, the circuit will not oscillate. The signal at the anode of the triode is 180° out of phase with that applied to the grid and the coupling arrangements must then ensure that the signal fed back to the grid is reversed by a further 180° to bring it back into phase again. This state of affairs is inferred in Fig. 341 (a). If we reposition the anode coil in the manner shown in Fig. 341 (b) the requisite phase relationship for oscillation to take place becomes more obvious.

<sup>5</sup>The correct expression for natural resonant frequency is  $\frac{1}{2\pi\sqrt{\frac{1}{LC} - \frac{R^2}{4L^2}}}$  where R is circuit resistance (including losses) in ohms. In normal practical radio applications, R is proportionately very low, and negligible error is introduced by ignoring it.

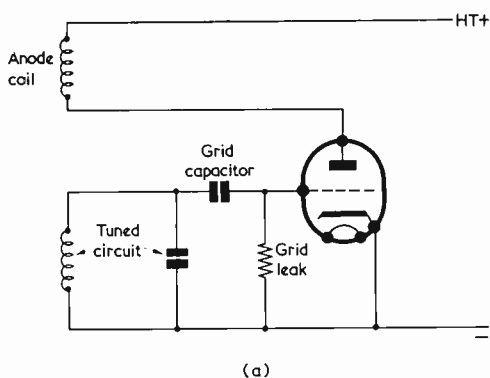

(a)

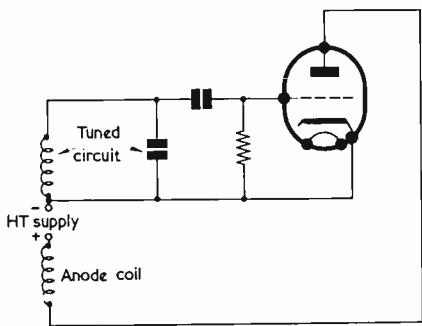

(b)

Fig. 341 (a). A simple triode oscillator. The anode coil is coupled inductively to the coil in the tuned circuit

(b). Repositioning the anode coil to demonstrate more clearly the phase relationships in the circuit

In the second diagram, the anode coil and the coil in the tuned winding take up the appearance of a single coil having a break in the middle into which is inserted the h.t. supply (which is assumed to have zero impedance). It can be seen that the alternating voltages at the ends of this single coil will be  $180^\circ$  out of phase with each other, with the result that conditions are correct for the anode signal to augment the signal at the grid. The feeding back of energy in phase, in the manner shown in Fig. 341 (b), is an instance of *positive feedback*. *Negative feedback*, it may be added, takes place when the output of an amplifier is fed back to the input out of phase.

The circuit of Fig. 341 (a) is "self-starting", in so far that it commences to oscillate as soon as supplies are applied to the triode and the valve has warmed up. Any small circuit disturbance which causes a variation in anode current will cause an oscillatory voltage to appear in the tuned circuit; this is then amplified by the valve and the amplitude of oscillation increases very rapidly until the full amplitude of which the circuit is capable is reached. The small change in anode current needed to start oscillations is normally due to the application of the supply, but it can be provided by even the tiny changes in anode current which result from variations in the quantity of electrons striking the anode inside the valve.

In a circuit of the type shown in Fig. 341 (a), the triode is described as an *oscillator* or *oscillator valve*. This name is, of course, due to the circuit in which the triode is placed.

#### Next Month

In next month's issue we shall examine the different types of oscillator, and discuss their performance.

## Series of Minibooks Announced by Mullard Educational Service

*Principles of Electrostatics* is the title of the first book in a new series of "minibooks" announced by The Mullard Educational Service.

Based on the successful series of filmstrips and slides produced by the Service, the new books are expected to become popular with both student and teacher.

*Principles of Electrostatics* is a 32-page book with an A5 international size format (15cm x 21cm). Its 13 sections each cover a particular aspect of electrostatics. Typical headings are: insulators and conductors, the electrification theory, the gold-leaf electroscope, capacitance and capacitors, electrostatic machines, electrostatic instruments.

Illustrations are black and white representations of the full colour artwork originally used in the filmstrip of the same name. Thus as well as being a useful work of reference in its own right, the Mullard "minibook" can also be used as illustrated lecture notes for teachers using the filmstrip and as handout material for classes seeing the strip.

*Principles of Electrostatics* is available from The Mullard Educational Service, Mullard Ltd., Mullard House, Torrington Place, London, W.C.1, price 2s. 6d. (including postage), cash with order. For bulk orders a discount is offered.

Details of the next Mullard "minibook" (*Principles of X-rays*) will be announced shortly.

# Amplifiers for Transistor Voltmeters

by C. Crosbie

*Transistors are nowadays cheaper than high sensitivity microammeters, and so the use of two or more transistors in voltmeter amplifiers represents an attractive proposition. In this article our contributor describes two basic transistor amplifier circuits he has constructed and tested himself, and gives details of the results obtained. The article does not include constructional information, and the amplifiers are presented as basic units which may be employed in conjunction with suitable series multiplier resistors*

**M**ANY CIRCUITS HAVE APPEARED for single transistor voltmeters, a typical example appearing in Fig. 1. These all have two disadvantages in common:

- (i) They are prone to zero-drift with temperature, this being due to the transistor being balanced against resistors in a bridge circuit. When a change in temperature occurs, the leakage current (and hence the resistance) of the transistor changes, causing the zero position to drift. This trouble can be overcome by balancing one transistor against another transistor.
- (ii) They have non-linear scales due to the transistor being operated at zero bias, i.e., "cut-off". This is necessary in single-transistor circuits as any attempt at biasing the transistor leads to shunting of the bias components by the circuit being measured. This second trouble may be overcome by

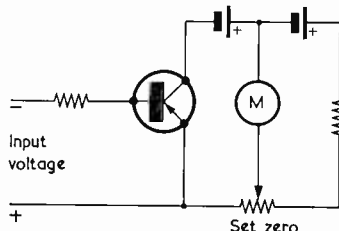

Fig. 1. A typical single-transistor voltmeter circuit

## Two-transistor Circuit

A basic two-transistor circuit is shown in Fig. 2. It may be seen from this that the collector voltages of the two transistors will be equal if they are both passing the same current. This condition is obtained by adjusting the potentiometer VR<sub>1</sub>. The adjustment of VR<sub>1</sub> does not, however, assure that the bases are at the same voltage. They need to be at

the same voltage for correct measurement, as any difference in voltage here will appear as an error in the measured voltage. In consequence, the bases are next short-circuited together, and VR<sub>2</sub> set for zero. Successive adjustments of VR<sub>1</sub> with the bases not connected together, and VR<sub>2</sub> with the bases short-circuited, will very quickly provide the correct zero setting. The function of R<sub>3</sub> is to provide a large amount of negative feedback to any common change in transistor currents, so that changes due to temperature variations common to both transistors will leave the meter unaffected.

The circuit of Fig. 3 was constructed, and the following performance obtained:

The input voltage for 1mA output was 50mV.

The sensitivity with the 1mA meter was 60kΩ/V.

The sensitivity would be increased proportionately by using a more sensitive meter, but it should be remembered that a more sensitive meter will also magnify the effects of zero-drift and any noise generated in

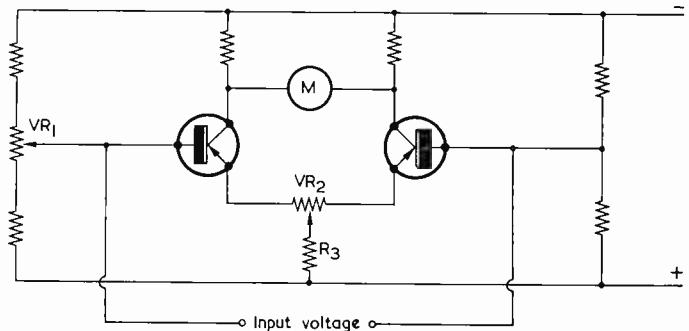

Fig. 2. A basic two-transistor circuit

applying the voltage to be measured to the bases of a pair of equally biased transistors. It is worth while using two transistors if the performance is significantly improved thereby, as the price of the two transistors is still only a fraction of the price of a sensitive meter.

either transistor. Thermal drift can be minimised by clamping the transistors to a common heat sink. Less drift will be encountered using silicon transistors. It is important to note, here, that many silicon transistors have the collector connected directly to the case.\* High stability resistors will add to the zero stability of the amplifier.

There was no noticeable drift or noise with the prototype Fig. 3 circuit except when one of the transistors was warmed by gripping between finger and thumb. When the other transistor was also gripped in this way, the zero point was regained.

Almost any pair of transistors may be used in this circuit. A succeeding

\* Sometimes the base is so connected, as with the BCY38.—EDITOR.



pair of transistors may be cascaded provided that it is intended to drive a coarser meter, say 10mA, as otherwise thermal drift will be excessive. Alternatively, the circuit may have overall negative feedback applied so as to reduce the voltage gain. This has the beneficial effect of decreasing the output impedance of the amplifier so that there remains a high power gain. In general only a small voltage amplification is required, between about 5 and 20. The inclusion of negative feedback in the circuit of Fig. 3 would have the effect of reducing the voltage gain and the output impedance of the amplifier,

$VR_3 = 2.5k\Omega$ .  
 $TR_{1,2,3,4} = OC201$  or  $OC202$ .  
 Meter =  $50\mu A$  f.s.d.  
 The tested sensitivity of the prototype circuit was  $4.8M\Omega/V$ . There was a tendency to very slight thermal wander (of less than  $\pm 1.5\mu A$ ) and a suggested cure could consist of employing a common clip for all transistors. Also,  $R_1$  could be in close proximity to  $R_8$ , and  $R_2$  to  $R_9$ .  
 Other meters than a  $50\mu A$  instrument may, of course, be used, less sensitive meters decreasing sensitivity. The final value of  $VR_3$  depends upon the gain of the transistors, the resistance of the

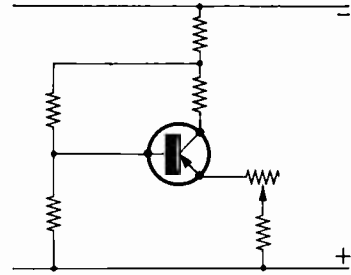

Fig. 4. Obtaining negative feedback with either of the transistors of Fig. 2

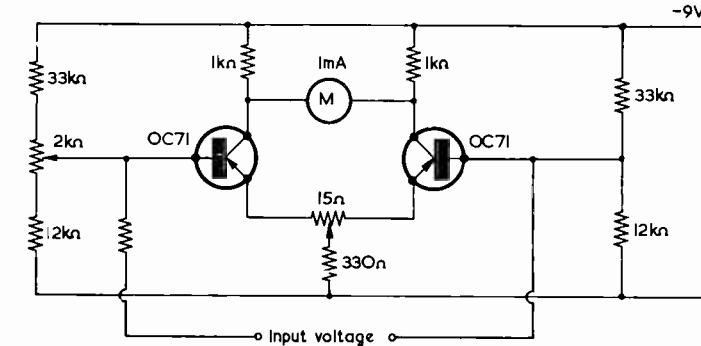

Fig. 3. A practical, tested, version of the two-transistor circuit, with components specified. The unidentified resistor in series with the input voltage terminals represents the voltage multiplier, and has a value appropriate to the range required

and making the circuit more stable with temperature changes. This can be done by taking the bias resistors to a tapping point in the collector resistor (see Fig. 4).

#### Four-transistor Circuit

For those who require a more stable, more sensitive amplifier, there is the four-transistor circuit configuration of Fig. 5. This represents very nearly the limit that can be obtained with present day transistors, unless "chopping" techniques are used. Chopper amplifiers are too complex for inclusion in this article.

The amplifier of Fig. 5 may be expected to provide  $50\mu A$  output for an input voltage of about 20mV. Its sensitivity will be about  $5M\Omega/V$ .

It is essential to use high grade silicon transistors for this circuit. The prototype was constructed with the following component values:

- $R_1 = R_2 = R_8 = R_9 = 510k\Omega$ .
- $R_3 = R_5 = R_6 = 680\Omega$ .
- $R_4 = R_7 = 68\Omega$ .

(All these resistors were  $\frac{1}{2}$  watt, 1%, high stability.)

- $VR_1 = 10k\Omega$ .
- $VR_2 = 5\Omega$ .

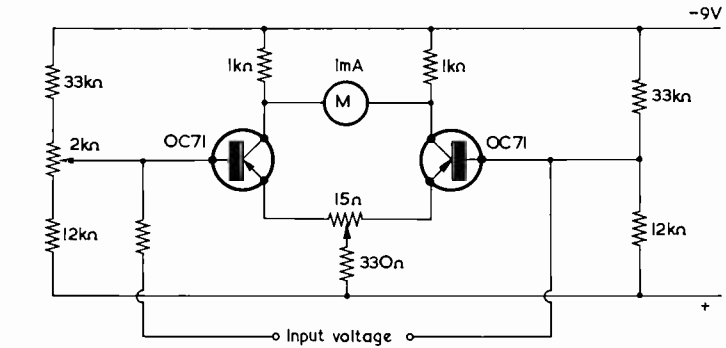

Fig. 5. A tested four-transistor amplifier. Component values are discussed in the text

meter and the required sensitivity (within that available). A value of  $2.5k\Omega$  for  $VR_3$  is suggested as a good start. If this turns out to be too high, the constructor will be able to shunt it down with a suitable resistor.

It should be noted that decreasing  $R_4$  and  $R_7$  from  $68\Omega$  to about  $22\Omega$  has the effect of decreasing sensitivity

( $M\Omega/V$ ) and decreasing the minimum voltage the amplifier can measure. This may suit some applications.

If  $VR_1$  has insufficient range to bring the meter to zero, then either  $R_1$  or  $R_2$  (as appropriate) should be shunted with several megohms, as required, so as to bring the meter to zero with  $VR_1$  in the middle of its travel.  $TR_1$  and  $TR_4$  should be of a low noise type if possible.

This article does not describe the connection of switches and resistors to convert the amplifier circuits to voltmeters. Once the sensitivity and input impedance have been determined, the two input terminals may be treated in the same way as if the amplifier were an ordinary meter.

#### Measurement of Alternating Quantities

The amplifier is capable of amplification up to a frequency determined by the transistors themselves. A meter rectifier could be used with some decrease of sensitivity, or an a.c. probe made. Alternatively a separate a.c. amplifier may be constructed.

# RADIO TOPICS . . .

by *Recorder*

**T**RANSISTORS WORK IN BOTH directions.

If you have a transistor connected in the earthed emitter mode then change over the emitter and collector leads, it will still amplify. This fact is fairly well-known, of course, and it stems from the symmetry of a transistor, in so far that it consists basically of two diodes back-to-back. With a p.n.p. transistor, for instance, you have a p.n. diode and an n.p diode, both sharing the same n section. Obviously, the transistor will not amplify so well when connected wrong way round because it was never intended for such an application. Nevertheless, it should still amplify, as I have recently checked with a few little experiments.

Incidentally, just because the particular issue in which this contribution appears happens to be that for April, please don't think that any leg-pulling is in progress!

## Practical Tests

To prove the point I carried out the following experiment with a few assorted p.n.p. transistors. I connected the positive terminals of a 3 volt battery and a 1.5 volt cell to the emitter of the transistor being tested. I next applied 3 volts negative from the battery to the collector via a testmeter switched to measure collector current. To the base of the transistor I applied 1.5 volts negative from the cell via a 15k $\Omega$  resistor and a 0-100 $\mu$ A meter. When this base bias (of slightly less than 0.1 mA) was applied, collector current flowed, whereupon the current gain of the transistor under these conditions was given by collector current divided by base current.

The next step was to transpose the emitter and collector leads of the transistor, altering no other part of the circuit. The collector now connected to the positive line and the emitter to the 3 volts negative line. Again, current from the 3 volt battery flowed when the base supply was connected and, again, the effective gain under these conditions was given by current from the 3 volt battery divided by base current.

The accompanying Table shows the results I obtained from this little experiment. The first column shows the transistor type checked, and the second column the current gain given when the collector was connected to the 3 volt negative line and the emitter was connected to the positive line. Base bias, as just mentioned, was from 1.5 volts negative of the emitter via a 15k $\Omega$  resistor, and the whole set-up represented the ultimate in orthodox respectability. The third column shows the current gain with the collector and emitter leads transposed.

Current gain with  $V_{ce}=3V$  and  $I_b \approx 0.1mA$

Transistor Type	Gain With Normal Connections	Gain With Emitter and Collector Transposed
OC72	100	2.5
OC72	67	1.7
OC44	50	15
OC44	110	8.5
ACY18	75	3.7
ACY18	48	4

As is to be expected, most of the gain figures in the third column are pretty low. The two OC72's offered gains of 2.5 and 1.7 only. One of the OC44's performed quite well, giving a gain of no less than 15 (jolly good transistors, these OC44's, for amplifying wrong way round) whilst the two ACY18's could only produce gains of 3.7 and 4. When reverse-connected, all the transistors drew negligible current from the 3 volt source until the bias from the 1.5 volt cell was applied.

To my mind the fact that amplification occurs under these conditions is an effect which does not seem to have been taken advantage of. Since a transistor functions in the manner I've just described it follows

that, when connected in the earthed base mode, it could amplify in both directions. Just the job, one would imagine, for telephone repeater applications.

However, whatever the uses may be, the effect still remains. If you feel like checking it for yourself, I would suggest you keep voltages and currents low to avoid the risk of damage to any transistor being checked. (To be really on the safe side you could, for example, use a collector voltage of 1.5 instead of 3.) I need hardly add that the effect demonstrates once more how many odd and sometimes unexpected things there are in this fascinating world of electronics.

## Mazda "Sparkguard" Base

Familiar to most service engineers by now is the appearance, on the printed circuit boards of recent television receivers, of spark-gaps which have been intentionally introduced into the printed circuit pattern. One section of each spark-gap connects to the focus electrode, or to the first anode, whilst the other connects to chassis. The function of the gap is to prevent damage to receiver circuitry should there be a spark inside the tube between the final anode and the electrode concerned. Flashover of this nature is liable to occur very occasionally on a very small proportion of tubes.

Thorn-AEI Radio Valves and Tubes, Ltd. have been paying special attention over the last four years to the improvement of picture brightness and resolution. The introduction of new c.r.t. screening processes and



The Mazda "Sparkguard" base, now fitted to all "Gold Star" television picture tubes. It can be identified by the connecting lug emerging from the side of the moulding

improved gun designs has resulted in a substantial improvement in c.r.t. light output for any given e.h.t. voltage and current, together with a more even focus over all parts of the screen. These improvements are incorporated in the Mazda "Gold Star" range of tubes. Furthermore, these Mazda tubes have now been uprated to 20kV, offering smaller spot size and better resolution.

It is the trend towards higher e.h.t. voltages which introduces the risk of occasional flashover in a minute quantity of the production, and for which spark-gaps on the printed board have been provided. However, Thorn-AEI have now introduced the new Mazda "Sparkguard" base, which brings the spark-gaps up to the tube itself. The Sparkguard base can be seen mounted on a Mazda tube in the accompanying photograph, and it will be fitted on all future production of "Gold Star" tubes.

The Sparkguard takes the form of a specially designed base moulding fitted over the tube base pins, which

includes within it two critically spaced spark-gaps. These gaps are between a metal plate and the first anode and focus electrode pins respectively. The plate is provided with an external connecting tag emerging from the side of the moulding, and this is connected by the setmaker to the external conductive coating of the tube. The setmaker is recommended to fit an isolating resistor of 2.2k $\Omega$  minimum in the first anode and focus electrode supply leads. With the spark-gaps located so near to the source of flashover the protection is more effective, and minimum disturbances pass into the remainder of the receiver circuit.

Service engineers need take no special precautions when fitting a Sparkguard tube into an earlier receiver but, if the full benefit is to be obtained, the connection from the metal plate to the external conductive coupling must be provided and the two isolating resistors added close to the base. The rating

of these resistors should be at least  $\frac{1}{2}$  watt in order to ensure that their physical size is sufficient to prevent surface leakage.

#### Not So New

Until a few days ago, I had always been under the impression that the term "high-fidelity" was coined after the war as a convenient means of qualifying the superior class of audio reproducing equipment which was then beginning to make its d but.

But I was mistaken, as I discovered when checking through the references at the end of the chapter on loudspeakers in F. Langford-Smith's classic *Radio Designer's Handbook*.

The reference in question was to the paper "A New Cone Loudspeaker For High Fidelity Sound Reproduction" by H. F. Olsen. And the date? January, 1934!

And, now, more than 32 years later, I must say cheerio for the time being. See you next month!

---

## British Microelectronics Manufacturers Join Forces

Two leading British electronics companies, Marconi and Ferranti, have announced that a licence agreement has been signed in a bid to win a major share of the growing world market for microelectronics. Under the terms of this new agreement, The Marconi Company will manufacture and sell the advanced range of silicon microcircuits designed and sold by Ferranti under the name of Micronor II.

This agreement will not only increase the production capacity available for this new range of integrated circuits, but will also provide users with the safety and convenience of a second source of supply. This is an important sales feature for this type of component, which will be used in quantity production equipment.

Extensive new production facilities for Micronor II are being commissioned by The Marconi Company at Witham, near Chelmsford, and by Ferranti, at their Manchester headquarters. The two companies already manufacture more than 70% of the silicon integrated circuits in the United Kingdom, and this new agreement will provide them with a greatly increased sales potential in world markets in this vitally important and rapidly expanding field.

Micronor II is a new range of ultra fast silicon integrated circuits designed for use in computer and other logic applications. They are available in many different circuits including multiple gates, power stages, J-K Flip Flops, etc., all of which have been subjects to twelve months intensive systems proving trials. The full range is already in quantity production in Manchester and it is anticipated that Government Qualification Approval will be obtained during 1966.

# LEARN ELECTRONICS AS YOU BUILD 25 CIRCUITS . . . EXPERIMENTS . . . TEST GEAR . . .

including

## ● CATHODE RAY OSCILLOSCOPE

- VALVE EXPERIMENTS
- BASIC AMPLIFIER
- BASIC RECTIFIER
- PHOTO ELECTRIC CIRCUIT
- TIME DELAY CIRCUIT
- SQUARE WAVE GENERATOR
- SIMPLE TRANSMITTER
- TRANSISTOR EXPERIMENTS
- BASIC OSCILLATOR
- ELECTRONIC SWITCH
- SIGNAL TRACER
- BASIC COMPUTER CIRCUIT
- BASIC RADIO RECEIVER
- MORSE CODE OSCILLATOR
- ETC. ETC.

This complete practical course will teach you all the basic facts of electronics by making experiments and building apparatus. You learn how to recognise and handle all types of components—their symbols and how to read a circuit diagram. You see how circuits are built and how they work **BY USING THE OSCILLOSCOPE PROVIDED.** Applications of all the main electronic circuits are

demonstrated—radio reception and transmission; photo-electrics; computer basics; timers; control circuits; etc.; including servicing techniques. **NO MATHS USED OR NEEDED. NO THEORY NEEDED. NO PREVIOUS KNOWLEDGE OR EXPERIENCE NEEDED.** Tutor service available. No extras needed—tools provided. Send now, for *Free Details* without obligation, to address below

**POST NOW**



To **RADIOSTRUCTOR**, Dept. K3, **READING, BERKS.** Please send free details of your electronics kit set to:

NAME .....

ADDRESS .....

## SMALL ADVERTISEMENTS

Use this form for your small advertisement

To: **The Advertisement Manager, Data Publications Ltd., 57 Maida Vale, London, W.9**  
 Please insert the following advertisement in the ..... issue of **THE RADIO CONSTRUCTOR**

16 words at 9d.  
= 12/-

**ALL WORDING  
IN  
BLOCK LETTERS  
PLEASE**

I enclose remittance of ..... being payment at 9d. a word. **MINIMUM 12/-.**  
 Box Number, if required, 2/- extra.

NAME .....

ADDRESS .....

*Copy to be received four weeks prior to publication. Published on the 1st of every month*

# SMALL ADVERTISEMENTS

Rate: 9d. per word.

Minimum charge 12/-.

Box No. 2/- extra.

Advertisements must be prepaid and all copy must be received by the 4th of the month for insertion in the following month's issue. The Publishers cannot be held liable in any way for printing errors or omissions, nor can they accept responsibility for the *bona fides* of advertisers. (Replies to Box numbers should be addressed to: Box No.—, *The Radio Constructor*, 57 Maida Vale, London, W.9.)

**SERVICE SHEETS, 1925-1965.** From Is. Catalogue 6,000 models, 1s. 6d. S.A.E. enquiries.—Hamilton Radio, 13 Western Road, St. Leonards, Sussex.

**HAMMERITE** hammer pattern brush paint, for panels and boxes, gives a perfect pattern in only 10 sec. Just brush it on!

Colours: Blue, silver or metallic black.

2½ oz. tins 3s. 6d. ½ gallon 35s.\*

½ pint 7s. 6d. 1 gallon 58s.\*

1 pint 15s. (\* sent by road).

Carriage: Orders up to 5s., 9d.; up to 10s., 1s. 9d.; over 10s., 2s. 9d.

Return of post service Monday to Friday.

From your component shop, or direct from the manufacturer: **FINNIGAN SPECIALITY PAINTS**, (RC), Mickley Square, Stocksfield, Northumberland. Telephone: Stocksfield 2280.

**GOVERNMENT SURPLUS** electrical and radio equipment. Our new catalogue No. 16 ready now, 2s. 6d. post free, cost refunded on purchase of goods over £2.—Arthur Sallis Radio Control Ltd., 93 North Road, Brighton, Sussex.

**FOR SALE.** Oscilloscopes—Galvanometers—Evershed & Vignolles Meggers. Also other items and components. Free list. Stamp please.—R. & E. Mart, Box 9 G.P.O., Tunbridge Wells, Kent.

**FIVE-TON FACTORY CLEARANCE.** Radio, TV, Electrical components in mixed parcels. Example: 22lb. mixed parcel £1 p.p. 7/6d. Speakers, grilles, valves, bases, i.f.'s, covers, condensers, etc. Hundred other items. S.A.E. list and postal orders to: P. Newton, 16 Shalcross Crescent, Hatfield, Herts.

**CONVERT ANY TV SET INTO AN OSCILLOSCOPE.** Instructions and diagrams, 12s. 6d.—Redmond, 42 Dean Close, Portslade, Sussex.

**STEREO RECORDS FOR SALE.** *Marches from Operas*, AF.FCS 50008; *Bob Sharples and His Music*, Decca SKL 4110; Unblemished at 10s. each.—Box No. F246.

**40 SEMICONDUCTORS** commonly used in radio and electronic circuits, consisting of 20 transistors OC42-45-71-81 etc., 10 silicon rectifiers 50-800 p.i.v. 200-800mA. Incl. BY100's plus 10 diodes OA70-79-81 zener and gold bonded. All brand new. Valued over £5. For only 40s. plus post and packing 1s. To:—**BI-PAK SEMICONDUCTORS, 8 RADNOR HOUSE, 93/97 REGENT STREET, LONDON W.1.**

**TRANSISTORS.** Good quality, close eqivs. OC71 1s. 9d. OC72 2s. OC44 2s. OC170 2s. 6d. OA70 8d. P. & P. 6d.—Wise, 19 Harbeck Road, Bournemouth, Hants.

*continued on page 589*

# BENTLEY ACOUSTIC CORPORATION LTD.

38 Chalcot Road, Chalk Farm, LONDON, N.W.1. PR11mrose 9090

47 Norfolk Road, LITTLEHAMPTON, Sussex. Littlehampton 2043

Please forward all mail orders to Littlehampton

0A2	5/9	6/30L2	8/9	AZ31	9/6	EF36	3/6	GZ33	14/6	PY800	5/9
0B2	6/-	9D7	7/6	DAF96	6/-	EF37A	7/-	GZ34	10/-	PY801	7/6
1L4	2/3	10C1	9/9	DF96	6/-	EF39	5/-	GZ37	14/6	U25	8/6
1R5	4/-	10C2	12/-	DK92	8/-	EF41	6/6	HABC80	9/3	U26	7/6
1S5	3/3	10F1	10/-	DK96	6/6	EF80	4/3	KT66	12/3	U191	9/6
1T4	2/3	10F18	9/9	DL96	6/6	EF85	4/6	PABC80	6/9	U301	11/-
2D21	5/6	10LD11	9/6	DM70	5/-	EF86	6/6	PC86	9/9	U329	9/-
306	3/9	10P13	12/-	DY87	7/6	EF89	4/3	PC88	9/-	U404	6/-
3Q4	5/3	10P14	11/6	EBBC8	13/6	EF91	3/-	PC95	6/9	U801	15/-
354	4/9	12AT6	4/6	EABC80	5/9	EF92	2/6	PC97	6/9	UABC80	5/6
3Y4	5/-	12AU6	5/9	EAF42	7/9	EF97	10/-	PCC84	5/6	UAF42	7/-
5Y3GT	4/9	12AV6	5/9	EB91	2/3	EF98	9/9	PCC85	6/9	UBC41	6/3
5Z4	7/6	12BA6	5/3	EBC41	6/6	EF183	7/3	PCC88	10/6	UBC81	6/3
6AQ5	5/9	12B56	4/9	EBC81	6/3	EF184	6/6	PCC89	11/6	UBF80	5/6
6AT6	3/9	12B+7	6/3	EBF8	5/9	EF190	9/6	PCC189	9/6	UBF89	6/3
6AU6	5/9	19AQ5	7/3	EBF83	7/3	EL33	6/6	PCF80	6/6	UC121	10/9
6AV6	5/6	20D1	10/-	EBF89	5/9	EL36	8/9	PCF82	6/-	UC92	6/3
6BA6	4/6	20F2	11/6	EBL21	10/3	EL41	7/-	PCF84	8/6	UCC84	8/-
6BE6	4/3	20L1	14/-	EC92	6/6	EL42	7/9	PCF86	8/3	UCC85	6/6
6BH6	5/3	20P1	12/6	ECC40	10/-	EL84	4/6	PCF801	9/9	UCF80	8/3
6BJ6	5/6	20P3	12/-	ECC81	3/6	EL85	7/6	PCF802	10/6	UCH21	8/-
6BQ7A	7/6	20P4	4/6	ECC82	4/6	EL86	7/3	PCL82	6/6	UCH42	8/-
6BR7	8/3	20P5	11/6	ECC83	4/6	EL95	5/-	PCL83	9/6	UCH81	6/6
6BRV6	7/6	30C15	10/-	ECC84	5/6	ELL80	13/6	PCL84	7/6	UCL82	7/3
6CD6G	18/-	30C17	11/9	ECC85	5/9	EM71	15/6	PCL85	8/6	UCL83	9/-
6CH6	6/6	30C18	9/3	ECC88	8/9	EM80	6/3	PCL86	8/9	UF41	6/9
6FI	9/6	30P5	7/3	ECC189	11/6	EM81	7/-	PEN45	7/-	UF42	4/9
6J5G	3/9	30PL1	9/3	ECC80	7/3	EL84	6/-	PL36	9/-	UF80	6/3
6J7G	4/6	30L15	10/3	ECCF82	6/3	EM85	8/9	PL38	16/-	UF85	6/9
6K7G	1/3	30L17	11/6	ECCF86	10/-	EM87	7/6	PL81	6/9	UF86	9/9
6K8G	3/3	30P12	7/6	ECH21	10/-	EY51	5/6	PL82	5/3	UF89	5/6
6L6GT	7/3	30P19	12/-	ECH35	6/-	EY81	7/3	PL83	6/-	UL41	7/-
6L18	10/-	30PL1	9/6	ECH42	8/-	EY83	9/3	PL84	6/3	UL84	5/6
6LD20	6/6	30PL13	10/6	ECH81	5/9	EY84	9/6	PM84	9/3	UM80	8/3
6O7GT	7/9	30PL14	11/3	ECF83	7/6	EY86	5/6	PY33	8/9	UY21	9/-
6SL7	4/9	30PL15	9/6	ECH84	9/6	EY88	8/9	PY80	4/9	UY41	5/-
6SN7	4/6	35W4	4/6	ECL80	5/9	EZ40	5/6	PY81	5/-	UY85	4/9
6V6G	3/6	85A2	6/6	ECL82	6/6	EZ41	6/3	PY82	4/9	VP48	12/-
6X4	3/9	8O7	11/9	ECL83	10/-	EZ80	3/9	PY83	5/6	X41	10/-
6X5	5/3	5763	7/6	ECL86	8/-	EZ81	4/3	PY88	7/3	X78	26/2

Terms of business: Cash with order only. No C.O.D. Post/packing 6d. per item. Orders over £5 post free. All orders despatched same day. Complete catalogue including transistor section and components with terms of business 6d. Any parcel insured against damage in transit for 6d. extra. We are open for personal shoppers 9 a.m.—5 p.m. Saturdays 9 a.m.—1 p.m.

## Any holes in your knowledge of TRANSISTORS?

Whatever your interest in transistor circuitry, you will find the Mullard "Reference Manual of Transistor Circuits" and "Transistor Radios—Circuitry and Servicing", valuable sources of reference.

The former describes more than sixty circuits for both domestic and industrial applications.

The latter is an introduction to the subject and describes the basic properties of semiconductors, their function, elementary circuitry and servicing.

REFERENCE  
MANUAL OF  
TRANSISTOR  
CIRCUITS  
U.K. PRICE  
12/6  
Post extra 1s.

TRANSISTOR  
RADIOS  
Circuitry and  
Servicing  
U.K. PRICE  
5/-  
Post extra 6d.



Get your copies from your radio dealer, or send remittance with order to:

MULLARD LTD. MULLARD HOUSE. TORRINGTON PLACE. LONDON WC1

# THE MODERN BOOK CO

**Radio Amateur's Handbook 1966.** By the A.R.R.L. 40s. Postage 2s. 6d.

**1966 World Radio TV Handbook.** 20th ed. 28s. Postage 1s.

**Understanding Lasers and Masers.** By S. Leinwoll. 13s. 6d. Postage 9d.

**Transistor Pocket Book.** By R. G. Hibberd. 25s. Postage 1s.

**Beginners' Guide to Electric Wiring.** By J. H. M. Sykes. 15s. Postage 1s.

**Transistor Substitution Handbook.** Pub. Foulsham-Sams. 12s. 6d. Postage 1s.

**Basic Theory and Application of Transistors.** U.S. Dept. Army. 10s. Postage 1s.

**The Radio Amateur's V.H.F. Manual.** Pub. A.R.R.L. 18s. Postage 1s. 6d.

**Hi-Fi Year Book, 1965/6.** By M. Henslow. 12s. 6d. Postage 1s.

**Transistor Receivers and Amplifiers.** By F. G. Reyer. 30s. Postage 1s.

**ABC's of Electronic Organs.** By N. H. Crowhurst. 16s. Postage 9d.

**Amateur Radio Call Book, 1966.** By R.S.G.B. 6s. Postage 9d.

**Science Projects in Electricity.** By E. M. Ncll. 24s. Postage 1s.

**Electric Guitar Amplifier Handbook.** By J. Darr. 24s. Postage 1s.

**Practical Microwave Primer.** By A. Camps and J. A. Markum. 30s. Postage 1s.

**Practical Transistor Servicing.** By W. C. Caldwell. 24s. Postage 1s.

**Building and Using Sound Mixers.** 30s. Postage 1s.

**Tape Recorder Servicing Manual.** By H. W. Hellyer. 63s. Postage 2s.

Complete Catalogue 1s.

We have the Finest Selection of English and American Radio Books in the Country

**19-21 PRAED STREET (Dept RC) LONDON W2**

Telephone PADdington 4185

## SPECIAL OFFER

1 Watt S.T.C. 300 Mc/s N.P.N. Silicon Planar 100% Transistors, £1 for 6.

3/- each OC44, OC45, OC70, OC71, OC81, OC81D, OC200, GET16, GET20.

4/- each AF114, AF115, AF116, AF117, OC170, OC171.

5/- each OC139, OC140, GET7, GET8, GET9, XC141, BY100, OA211.

### SUN SOLAR CELL KIT

4 Sun Solar Cells plus 24-page Booklet on Experiments, 11/- set.

### G.P.O. DIAL TELEPHONES

20/- each 35/- pair

Send 6d. for Full Lists including S.C.R. Zeners, etc.

## CURSONS

78 BROAD STREET, CANTERBURY, KENT



### MAKE 5 DIFFERENT RADIOS FOR 35/-

Amazing Radio Construction Set! Become a radio expert for 35/-! A complete Home Radio Course. No experience needed. Parts include instructions for each design, Step-by-Step plan, all Transistors, loud-speaker, personal phone, knobs, screws, etc., all you need. Box size 14" x 10" x 2" (parts available separate). Originally £6. NOW 35/- plus 3/6 p. & p.

### NEW RADIO ONLY 19/6



New RADIO Any-one CAN BUILD in 2-3 hours! Only 19/6. EVEN THE OLDER CHILDREN BUILD THEM! No soldering.

Only 16 connections! Then hear it reach out bringing in station after station. 4 1/2" x 2 1/2" x 1 1/2". Many Testimonials: M.H. of Bradford, writes: "... I have just completed one of your sets successfully, it is the first time I have ever tackled anything like a radio and I must state here and now, I am amazed how easy it is to a layman like me. Your instructions and plan have obviously been very carefully thought out so that even the most dim can follow them. ..." 19/6 plus 2/6 post, etc.

### ASTONISHING CIGARETTE RADIO

Yes a perfectly ordinary packet of cigarettes—but it fetches in station after station, loud and clear! Holds 10 Cigarettes—yet cleverly conceals highly sensitive, fully transistorised circuit (incl. tiny battery). Even a young boy can assemble it in under 2 hours. No soldering. No experience necessary. Only 16 connections. From our bulging testimonial file Mr. D. B. of Huddersfield writes: "... I have fitted the parts in and it is working wonderfully. ..." ALL PARTS including Semi-Conductors, A.B.C. Plans, etc. ONLY 18/6 plus 2/6 post, etc.



CONCORD ELECTRONICS LTD (Mail Order Only) (Dept. R.C.11.) 77 NEW BOND STREET W.1

## SMALL ADVERTISEMENTS

continued from page 587

**WANTED.** Information on meteorological FAX radio reception systems, brochures, circuits, surplus equipment, etc.—Box No. F250.

**WANTED.** To purchase secondhand classical L.P. records in good condition. Reasonable.—Box No. F251.

**WANTED.** Plug-in coils for the wartime H.R.O. receiver.—R. & E. Mart, Box 9, G.P.O., Tunbridge Wells, Kent.

**FOR SALE.** RTTY converter, Type A.P. 66286, £5 plus carriage.—Box No. F254.

**EXPERIMENTER'S TRANSISTORS.** All oscillate 2.5Mc/s, 3s. 6d. doz. plus s.a.c.—Lcening, 185 Brandy House Brow, Blackburn, Lancs.

**WANTED.** Copy of Harmsworth's *Wireless Encyclopedia* (published approximately 1925).—Box No. F257.

**COMPLETE CLEARANCE.** Components, etc. Too numerous to advertise. Inexpensive. S.A.E. list.—2 Fitzgerald Avenue, Seaford, Sussex. Telephone: 4961.

**SILICON SEMICONDUCTORS.** 2N2926 Planar n.p.n. 18V 200mW HFE 55-180 4s. each; 150-470 5s. each. 2N2646 UJT suitable for rev. counters, timers, etc. 15s. each. SCR 300V 7.4 amps 40s. each. S.A.E. for full list.—Box No. F258.

**FOR SALE.** Heathkit Balun Coil Unit, B-1U. £4.—Box No. F259.

**BOOKS TO CLEAR.** "Transistors work like this" (Larsen) 5s. "Electronic Music & Musique Concrete" (Judd) 7s. 6d. "The Technical Writer" (Godfrey & Parr) 17s. 6d. "Man in Space" (Haber) 10s. "Realities of Space Travel" (Carter) 10s. "The Story of Astronomy" (Draper and Lockwood) 5s. "Santos-Dumont" (Peter Wykeham) 17s. 6d. "Teach Yourself Russian" 5s. "The Manual of Rugby Union Football" 5s. "How to develop a Super-Power Memory" (Harry Lorayne) 10s. "The Principles of Modern Book-Keeping" (Hamilton) 5s.—Box No. F260.

**FOR SALE.** 2.5 watt push-pull audio amplifier 38s. Also mains p.u. for transistor radio 12s.—Box No. F261.

**"MEDIUM WAVE NEWS"** Monthly during DX season—Details from: B. J. C. Brown, 60 White Street, Derby.

**TECHNICAL DRAWINGS, Artwork, etc.** Electronic and Radio Circuits a speciality. Moderate charges.—B. P. Meaney, 43 Forest Road, Worthing, Sussex.

**JOIN THE INTERNATIONAL S.W. LEAGUE.** Free Services to members including Q.S.L. Bureau. Amateur and Broadcast Translation. Technical and Identification Dept.—both Broadcast and Fixed Stations, DX Certificates, contests and activities for the SWL and transmitting members. Monthly magazine, *Monitor*, containing articles of general interest to Broadcast and Amateur SWLs, Transmitter Section and League affairs, etc. League supplies such as badges, headed notepaper and envelopes. QSL cards, etc., are available at reasonable cost. Send for League particulars. Membership including monthly magazine, etc., 35s. per annum.—Secretary, ISWL, 60 White Street, Derby.

continued on page 591

# 2 FREE GIFTS

INSIDE EVERY COPY!

## FREE!

## RESISTOR COLOUR CODE CALCULATOR

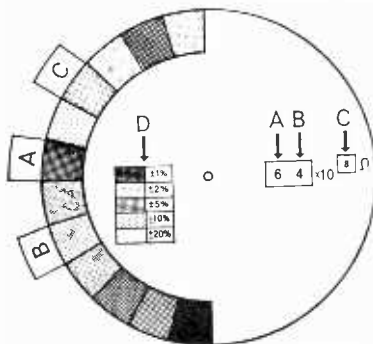

For easy reference just set the colours and the correct resistance value appears in the "window". Also shows resistor tolerance

## FREE!

## 24-PAGE GUIDE TO VALVE CIRCUITS

At-a-glance data on r.f., i.f. and a.f. amplifiers, frequency changers, oscillators and many other aspects of radio and electronic equipment



## NEW LARGER-SIZE FORMAT

# PRACTICAL WIRELESS

MAY ISSUE OUT APRIL 7th 2/6

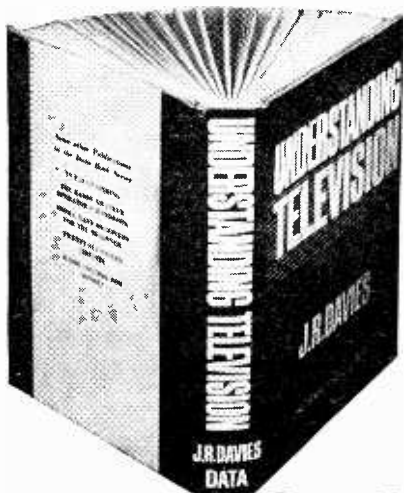

# UNDERSTANDING TELEVISION

by

J. R. Davies

Over 500 pages 300 diagrams **37/6**

Postage 2/6d

UNDERSTANDING TELEVISION deals with:—

- Principles of 405 line reception
- Nature of the television signal
- Receiver tuner units
- A.F. and video amplifiers
- Deflector coil assemblies
- Automatic gain and contrast control
- Receiver aerials
- Principles of 625 line reception
- The cathode ray tube
- Receiver i.f. amplifiers
- Vertical and horizontal timebases
- Synchronising
- Power supply circuits
- Colour television
- **COLOUR TELEVISION**—80 page section deals comprehensively with this subject

The reader is required to have only a basic knowledge of elementary radio principles. The treatment is non-mathematical throughout, and there is no necessity for any previous experience in television whatsoever. At the same time, UNDERSTANDING TELEVISION is of equal value to the established engineer because of the very extensive range it covers and the factual information it provides.

---

**To Data Publications Ltd., 57 Maida Vale, London, W9**

Please supply.....copy(ies) of your latest publication "Understanding Television", Data Book No. 17. I enclose cheque/crashed postal order for .....

NAME.....

ADDRESS .....

.....

.....



## SMALL ADVERTISEMENTS

continued from page 589

**ARE YOU A MOTORING ENTHUSIAST?** The Seven Fifty Motor Club caters for all types of motor sport—racing, rallies, hill climbs, etc. Monthly Bulletin free to members. For full details write to: The General Secretary, Colin Peck, "Dancer's End", St. Winifred's Road, Biggin Hill, Kent.

**POSTAL ADVERTISING?** This is the Holborn Service. Mailing lists, addressing, enclosing, wrapping, facsimile letters, automatic typing, copy service, campaign planning, design and artwork, printing and stationery. Please ask for price list.—The Holborn Direct Mail Company, 2 Mount Pleasant, London, W.C.1. Telephone: TERminus 0588.

### EDUCATIONAL

**TV AND RADIO.** A.M.I.E.R.E., City & Guilds, R.T.E.B. Cert., etc., on "Satisfaction or Refund of Fee" terms. Thousands of passes. For details of Exams. and home training courses (including practical apparatus) in all branches of radio, TV and electronics, write for 156 page Handbook—FREE.—B.I.E.T. (Dept. 141K), 29 Wright's Lane, London, W.8.

## MORSE MADE !!

EASY !!

The famous RHYTHM RECORDED COURSE cuts practice time down to an absolute minimum!

One student, aged 20, took only 13 DAYS and another, aged 71, took 6 WEEKS to obtain a G.P.O. pass certificate. If you wish to read Morse easily and naturally, please enclose 8d. in stamps for full explanatory booklet to:—

G3CHS/D, 45 Green Lane, Purley, Surrey.

### (500/10) SEMICON-INF SERVICE

Specialist suppliers of all types of semiconductor devices and quality components. Send 9d. in stamps for data summary of our stock range. NEW detailed Price list available during APRIL.

**400mW ZENER DIODES—DO-7 outline.**

Z.F. series. (Tolerance 5%) Range 2.7 to 33 Volts. All at 8/6 each.

**VARIACAP DIODES—DO-7 outline.**

Type	VR volts	VF @ 60mA	Capacitance Range (a) VR 2V and f 30 Mc/s	Q Factor	Price
BA 110	30	0.95	8—12	540	6/3
BA 111	30	0.95	45—65	200	8/—
BA 112	30	0.95	80—120	100	13/6
BA 119	50	1.1	8—12	100	9/—
BA 120	50	0.9	45—65	300	9/7

**TUNNEL DIODES—Miniature axial package**

Type	Peak point current IP	Valley point current IV	Package capacitance	f <sub>ro</sub> Mc/s	Price
IN3716 (TD-3)	4.7mA ± 10%	1.04mA	50pF	1800	34/6
IN3718 (TD-4)	10.0mA ± 10%	2.2mA	90pF	1600	34/6
IN3720 (TD-5)	22.0mA ± 10%	4.8mA	150pF	1600	25/9

**PACKAGED CIRCUITS—AUDIO AMPLIFIER**

Type	Input impedance	Supply voltage	Sensitivity	Output power	Price
PC 1	1.5 K	9	100mV	150mW	37/6
PC 2	1.0 K	9	2mV	400mW	52/6
PC 3	2.5 K	9	10mV	400mW	52/6
PC 4	220.0 K	9	200mV	400mW	52/6
PC 5	1.5 K	12	5mV	3 Watts	105/—
PC 7	1.5 K	9	5mV	1 Watt (nominal)	69/3

**PACKAGED CIRCUITS—POWER SUPPLY**

Type	DC output (a) voltage	Max. Load current	Max. Ripple volts (rms)	Input voltage	Price
PC 101	9	150mA	200mV	240V ac	37/6
PC 102	21	320mA	110mV	200-250V ac	62/—
PC 106	12	500mA	600mV	200-250V ac	52/6

**MINIATURE CARBON FILM RESISTORS—Range 4.7 ohm to 1 Meg. Ohm. ± 5% One-eighth Watt. Dimensions 8 mm. x 2.7 mm. diameter. 9d. each. (2% range also available.)**

**NEW RANGES OF TRANSISTORS, DIODES, SCR's and COMPONENTS** are being added each month. Quotations will be supplied to meet your requirements.

Please add 1/- Postage & Packing on all orders of £2 or less.

TERMS: C.W.O. MAIL ORDERS ONLY PLEASE.

**M. R. CLIFFORD & CO. (R)**

66 Old Oscott Lane, Birmingham, 22A.



ESTABLISHED

1865

Savings in this old established Building Society combine sound investment with an attractive return

## THE DUCHESS OF KENT PERMANENT BUILDING SOCIETY

Member of the Building Societies Association

Shares are in units of £25 each (maximum investment £5,000) . . . BUT, for the smaller saver, Subscription Share accounts may be opened with any sum from 1/- upwards. Interest is payable half-yearly on Fully Paid Shares—credited annually on Subscription Shares—all interest accrues monthly

Withdrawals at short notice

**INTEREST IS AT 4% PER ANNUM**

(There is NO DEDUCTION FOR INCOME TAX, as this is paid by the Society)

For further information apply to

**DUCHESS OF KENT  
PERMANENT BUILDING SOCIETY**

289/293 Regent Street London W1

Telephone MUSEum 4876-9

Please send to me, without obligation, free brochure and a copy of the audited statement of accounts. (I understand that I shall not be troubled with calls by representatives)

Name .....

(If lady, please state Mrs. or Miss)

Address .....

R.C.

(Please use Block Capitals for both name and address)

# CHASSIS and CASES by



287/9 Edgware Road  
London W2  
TELEPHONE  
PADDINGTON 5891/7595

## BLANK CHASSIS—Same Day Service

Of over 20 different forms made up to YOUR SIZE.  
(Maximum length 35", depth 4".)

### SEND FOR ILLUSTRATED LEAFLETS

or order straight away, working out total area of material required and referring to table below which is for four-sided chassis in 16 s.w.g. aluminium.

48 sq. in.	4/3	176 sq. in.	9/-	304 sq. in.	13/6
80 sq. in.	5/6	208 sq. in.	10/-	336 sq. in.	14/9
112 sq. in.	6/6	240 sq. in.	11/3	368 sq. in.	15/9
144 sq. in.	7/9	272 sq. in.	12/6	and pro rata	
	P. & P. 3/-		P. & P. 3/6		P. & P. 4/-

Discounts for quantities. More than 20 different sizes kept in stock for callers.

**FLANGES** (1/2" or 3/4"), 6d. per bend.  
**STRENGTHENED CORNERS**, 1/- each corner.  
**PANELS**

Any size up to 3ft at 5/3 sq. ft. 16 s.w.g. (18 s.w.g. 4/6).  
Plus postage and packing

### CASES

#### ALUMINIUM, SILVER HAMMERED FINISH

Type	Size	Price	Type	Size	Price
U	4 x 4 x 4"	10/-	Y	8 x 6 x 6"	26/6
U	5 1/2 x 4 1/2 x 4 1/2"	15/-	Y	12 x 7 x 7"	41/-
U	8 x 6 x 6"	21/-	Y	13 x 7 x 9"	46/-
U	15 x 9 x 9"	44/6	Y	15 x 9 x 7"	48/6
W	8 x 6 x 6"	21/-	Z	17 x 10 x 9"	66/-
W	12 x 7 x 7"	34/-	Z	19 x 10 x 8 1/2"	71/-
W	15 x 9 x 8"	44/-		* Height	

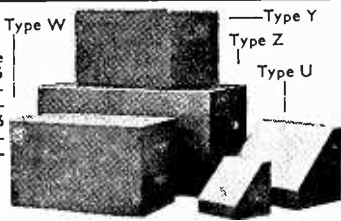

Type Z has removable back and front panels.  
Type Y all-screwed construction.

## BRASS · COPPER · LIGHT ALLOYS · ALUMINIUM BRONZE · STAINLESS STEEL

ROD, BAR, SHEET, TUBE, STRIP, WIRE. 3,000 STANDARD STOCK SIZES  
No Quantity too small List on application

**H. ROLLET & CO LTD**  
HOWIE ST. LONDON SW11 BATTERSEA 7872  
Also at Liverpool, Birmingham, Manchester, Leeds, Glasgow

## AERIAL MATCHING TUNING UNITS

These well-made tuning units, made for the American 19Tx-Rx are housed in a metal case, green or brown, using a large precision calibrated scale, are an essential piece of equipment for the serious Tx or Rx operator. This unit will match an untuned wire or whip aerial to almost any short wave receiver or transmitter, exceptionally good for mobile Top Band use. This American version being well noted as far superior to any other. **GUARANTEED BRAND NEW**, only 20/-, post 7/6. Instructions supplied.

**JOHN'S RADIO**  
OLD CO-OP, WHITEHALL RD., DRIGLINGTON, BRADFORD

the unique **PANL** black crackle paint

4/-d. per 1/8 pt. Can  
(We regret we can only supply on cash with order basis)

**BRUCE MILLER LTD.,**  
249 Coastal Chambers,  
Buckingham Palace Road, S.W.1.

## RADIO AMATEUR'S HANDBOOK

1966 Edition

By A.R.R.L. 40/- Postage 2/6d.

Obtainable from:—  
**THE MODERN BOOK CO.**  
DEPT. RC, 19-21 PRAED STREET, LONDON, W.2

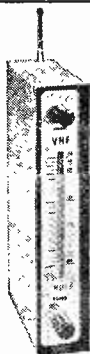

## TELECOM MK. II

Pocket size V.H.F. 118-136 Mc/s

### AIRCRAFT-BAND TRANSISTOR RECEIVER

complete with telescopic aerial,  
loudspeaker and battery

£26.0.0  
carr. paid in U.K.

**BRITE LIMITED**  
17 Charing Cross Road, London, W.C.2  
Whitehall 3070

## YUKAN SELF-SPRAY

SO PROFESSIONAL  
THE YUKAN  
AEROSOL WAY!

GET THIS AIR DRYING **HAMMER FINISH**  
**NOW!**

Open all day Saturday  
YUKAN Aerosol spraykit contains 16 ozs. fine quality, durable, easy instant spray. No stove baking required. Available in Grey, Blue, Gold, Bronze at 14/11 at our counter or 15/11, carriage paid, per pushbutton self-spray can. **SPECIAL OFFER:** 1 can plus optional transferable snap-on trigger handle (value 5/-) for 18/11 carr. paid.



Choice of 13 self-spray plain colours and primer (motor car quality) also available.

Please enclose cheque or P.O. for total amount to:  
**YUKAN · DEPT RC/4 · 307a EDGWARE ROAD · LONDON · W.2**

## THE RADIO CONSTRUCTOR — BOUND VOLUMES

NOW AVAILABLE

Volume 18, August 1964 to July 1965. Price £1 10s. 0d. Postage 3s. 6d.

Where all issues are returned: Price £1. Postage 3s. 6d.

We regret earlier volumes now sold out.

Send for list containing details of our other publications

**DATA PUBLICATIONS LTD 57 MAIDA VALE LONDON W9**

Please mention **THE RADIO CONSTRUCTOR** when writing to advertisers

# BOOK LIST

## DATA BOOKS SERIES

### DB5 TV Fault Finding

96 pages. Price 6/-, postage 6d.

Profusely illustrated with photographs taken from a television screen depicting the faults under discussion and containing a wealth of technical information, with circuits, enabling those faults to be eradicated.

Covers both B.B.C. and I.T.A.

"... A book that should be in every television dealer's service workshop, and in every home-constructor's, for that matter."—*Journal of the Television Society*.

### DB6 The Radio Amateur Operator's Handbook

64 pages. Price 5/-, postage 5d.

Contains Amateur Prefixes, Radio Zone Boundaries, Amateur Band Frequency Allocations, Call Areas, Charts and Maps, Areas, Codes, Mileage Tables, Prefixes/Directional Bearings, Post Office Regulations, and much other useful operating data. For the beginner there are notes on how to use the mass of information given to obtain the greatest satisfaction from the hobby.

"... For concise knowledge in this field a few shillings well worth spending."—*Electronics (Australia)*.

### DB14 Short Wave Receivers for the Beginner

72 pages. Price 6/-, postage 6d.

Contains a selection of both battery and mains operated short wave receivers, circuits, point-to-point wiring diagrams and many illustrations. Introductory chapter gives much information on the Short Wave Spectrum, Clubs, QSL'ing, Aerials, Amateur and Broadcast Band Listening, Frequencies, etc.

This book has been specially prepared for the beginner interested in short wave receiver construction and operation.

### DB15 Twenty Suggested Circuits

48 pages. Price 3/6, postage 5d.

By G. A. French. Covers subjects ranging from electronic laboratory equipment to the simplest of periodic switches. Includes: simple and inexpensive two-valve capacity bridge, short wave regeneration preselector, one-valve speech operated switching circuit, transformer ratio analyser, series noise limiter, receiver remote mains on-off control, and many other circuits.

### DB16 Radio Control for Models

192 pages. Price 15/-, postage 9d.

By F. C. Judd. Contains both theory and practical designs of simple and advanced transmitters and receivers; basic concepts, aerials, uses of radio components, transistorised receivers, multi-channel operation, etc. Sections on servo-mechanisms by Raymond F. Stock.

More than 200 illustrations. Circuits, photographs, tables and working diagrams.

### DB17 Understanding Television

512 pages. Price 37/6, postage 2/6

By J. R. Davies. This book, which deals with the principles of 625 line reception as fully as 405 line reception, fully explains: the nature of the television signal; the cathode ray tube; receiver tuner units; receiver i.f. amplifiers; a.f. and video amplifiers; vertical and horizontal timebases; deflector coil assemblies; synchronising; automatic gain and contrast control; power supplies and receiver aerials. Also includes a comprehensive introduction to colour television.

"... one of the best books that aims to explain television in simple language . . ." R.S.G.B. Bulletin.

I enclose Postal Order/Cheque for .....

NAME .....

ADDRESS .....

(Please use Block Capitals for both name and address)

Postal Orders should be crossed and made payable to Data Publications Ltd.

Overseas customers please pay by International Money Order

All publications are obtainable from your local bookseller

Data Publications Ltd., 57 Maida Vale, London W.9

# 1966 150 BIG PAGE CATALOGUE

5,000 stocked items. Fully detailed and illustrated. FREE vouchers give 2/- in (post paid) the £ discount.

# PROVED & TESTED DESIGNS

## FULL AFTER SALES SERVICE AND GUARANTEE

Largest range available of components and accessories  
Let us quote for your circuit

DETAILED LEAFLETS FREE ON REQUEST

FREE New 16 page catalogue 500 transistors, rectifiers, scrs, light devices, heat sinks, 1,000 crystals, 800 valves, etc. Ask for your FREE copy NOW

### MW/LW POCKET SUPERHET RADIO



**RADIO**  
TOTAL COST TO BUILD **85/-** P.P. 2/-  
(Battery 2/6 Phone 5/-)

★ All parts sold separately.

- ★ 6-Transistor design. Push-pull output.
- ★ 2 1/2" Clearstone speaker. Printed circuit.
- ★ Attractive moulded cabinet.
- ★ Slow motion tuning.
- ★ Full medium and long waves.
- ★ Size: 5" x 3" x 1 1/2".

● **AMAZING SENSITIVITY AND SELECTIVITY**

- ★ 6-Transistor push-pull design.
- ★ Uses factory built panels.
- ★ Permeability geared tuning.
- ★ Full med./long wave tuning with push-button wave change.
- ★ Double tuned IFT's.
- ★ Chromed front panel plate.
- ★ Size: 7" x 4" x 2". Fits any car.
- ★ Pre-built units sold separately.

TOTAL COST TO BUILD **£8.19.6** P.P. 3/6



(7" x 4" speaker with car fixing kit and baffle board 20/- extra.)

**TWO WAVEBAND ALL-TRANSISTOR CAR RADIO TO ASSEMBLE**  
● **HIGH PERFORMANCE SUPERHET**

### 2- AND 4-TRACK TAPE RECORDERS TO ASSEMBLE

Pre-built Equipment—6 Valves—Collaro Studio Decks—Portable Cabinets with Speakers. Complete record and playback.



★ 2 track deck 10 gns. P.P. 5/-.

★ 4-track deck £13.10.0. P.P. 5/-.

OR SPECIAL PRICE **£30** P.P. **FOUR TRACK** (Now with new '363' decks) 8/6

Prebuilt and tested units. Low distortion, low noise

### 10W & 20W HI-FI AMPLIFIERS

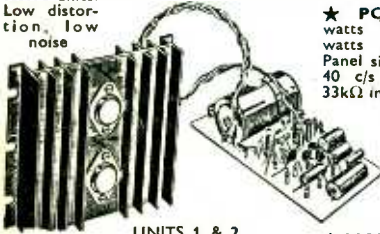

UNITS 1 & 2

★ **POWER AMPLIFIERS.** 10 watts R.M.S. music power, 20 watts peak. 6-Transistor design. Panel size 4" x 2 1/2" x 3". Response 40 c/s to 20 kc/s. 100mV into 33kΩ input.

**UNIT 1.** For 12/15 ohm speakers. 40 volt supply. PRICE BUILT **£5.19.6** P.P. 2/6

**UNIT 2.** For 3 to 5 ohm speakers. 24/28 volt supply. PRICE BUILT **£5.10.0** P.P. 2/6

★ **MAINS UNITS.** 59/6. To power one amplifier or 69/6 to power two amplifiers. (State 24 or 40-volt version.)

**PREAMPLIFIERS.** Mono and stereo versions, 8 inputs, 1 1/2 to 300mV at 1k to 500k. Response 30 c/s to 20 kc/s. Complete range of controls. Mains unit or battery operated. For pickups, tuners, tape, microphones, etc.

**UNIT 3.** Mono full-function pre-amplifier. Size 9 1/2" x 2 1/2" x 2".

PRICE BUILT **£5.10.0** P.P. 2/- (Brown/Gold front panel plate 8/6)

**UNIT 4.** Simplified version of Unit 3. Price 65/- P.P. 1/6. Panel plate 6/6.

**UNIT 5.** Stereo preamplifier for use with two units 1 or 2. Size 9" x 3 1/2" x 1 1/2".

PRICE BUILT **£10.19.6** P.P. 3/6 (Front panel plate 12/6)



UNIT 5

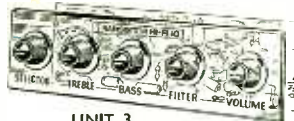

UNIT 3

**THE FINEST QUALITY HI-FI AT UNBEATABLE PRICES**

### TRANSISTOR TRANSMITTER RECEIVERS



★ 1/2 mile range, price per pair **£7.19.6**

★ 5 mile range, price per pair **£22.10.0**

### 4-CHANNEL MICROPHONE MIXER



Transistorised, 4 inputs up to 100kΩ. Full mixing. 49/6 Stereo 72/6

### SINCLAIR FM RADIO POCKET VHF Kit £5.19.6

X20 AMPLIFIER Kit £7.19.6

Z12 AMPLIFIER 89/6

MICRO-6 MW RADIO 59/6

### 5 WATT AND 1 1/2 WATT PACKAGED AMPLIFIERS

★ 6-Transistor push-pull printed circuit designs.

★ Size only 2 1/2" x 2" x 1 1/2".

★ 5 watt 18 volt, 1 1/2 watt 12 volt.

★ For 3 to 5 ohm speakers.

★ 7mV into 1kΩ 30 c/s to 16 kc/s. PRICES BUILT 1 1/2w 65/- P.P. 1/6 5w 79/6 P.P. 1/6



### ● Mono PREAMPLIFIER

Full range of controls, inputs for mics, p-u., tuner, etc. Output 6-10mV. Suitable for any sensitive transistor amplifiers as above. 7 1/2/12/18V operated. Price built/tested incl. panel 79/6. P.P. 2/6.

### HI-FI ALL MAKES AVAILABLE—New Hi-Fi Demonstration Room now open



**TRANSISTOR PORTABLE TEST EQUIPMENT**  
All units size 6 1/2" x 4 1/2" x 2 1/2".

★ RF generator, 150 kc/s to 350 Mc/s in 8 ranges. RF, Mod. RF, AF outputs.

PRICE **£9.10.0** P.P. 2/6

- ★ Resistance/capacitance bridge. £8.5.0. P.P. 2/6.
- ★ Audio generator 10 c/s-100 kc/s. 4 ranges. £16.15.0. P.P. 2/6.



**VHF/FM TUNER TO ASSEMBLE**

★ Two pre-built plus metal work and front panel. Total Cost **£12.17.6**

- ★ Size: 9 1/2" x 3 1/2" x 4".
- ★ 88 to 108 Mc/s tuning.
- ★ 100mV to 100kΩ output P.P. 2/6.
- ★ 6-Transistor printed ccc. superhet design.

### NEW SW/MW/LW PUSH-BUTTON PORTABLE TO BUILD. 3 wavebands

TOTAL COST **£8.19.6** P.P. 3/6

The only fully Tunable 3-waveband radio for home construction.



- ★ Push-button coil pack.
- ★ 1 watt push-button output.
- ★ Ferrite aerial/Telex. aerial/special car coils.
- ★ Printed circuit 6-transistor design.
- ★ SW 17/50m. LW 1100/1900m. MW 195/550m.
- ★ Car aerial and tape sockets.
- ★ Attractive sturdy cabinet with handle. Size 11" x 7 1/2" x 3 1/2". Black fabric with chrome fittings.

LET US QUOTE PARTS FOR YOUR CIRCUIT, SEND LIST FOR QUICK REPLY

### VHF/FM TRANSISTOR TUNER TO BUILD

TOTAL COST **£6.19.6**

P.P. 2/6 (complete with frontplate) (Goldsprayed cabinet 20/- extra).



- ★ 5-Transistor 4 diodes.
- ★ Printed circuit superhet.
- ★ Geared tuning 87 to 105 Mc/s FM.
- ★ RF stage and double tuned IFT's.
- ★ Output up to 1 volt peak up to 100kΩ.
- ★ 9 volt 9mA supply.
- ★ Size in cabinet 4" x 3 1/2" x 2 1/2".
- ★ All parts sold separately.

**HENRY'S RADIO LTD.**  
303 EDGWARE ROAD, LONDON, W2  
PADdington 1008/9

Open Mon. to Sat. 9-6. Thurs. 1 p.m.  
Open all day Saturday